

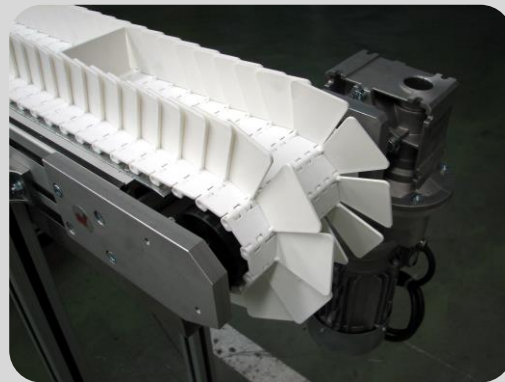

NT 500

Transportador de banda modular
Modular plastic belt conveyor.



 NIKAI SYSTEMS dispone de un gran abanico de transportadores de banda articulada modular para ajustarse a la forma y al peso del producto a transportar o bien dependiendo de la disposición física donde ha de instalarse el equipo.

Las aplicaciones más usuales para estos equipos se engloban en los sectores de la alimentación, empaquetado, embotellado, automóvil, etc.

Para el sector de alimentación se utilizan bandas articuladas que cumplen con la normativa FDA. A diferencia con los transportadores de banda de tejido, el arrastre de la banda no se realiza por fricción sino por tracción de piñón a la banda articulada, por lo tanto las tensiones de la banda son menores y el ajuste de las mismas es muchísimo más fácil y rápido.

La unión de los diferentes módulos que componen la banda se realizan por medio de pasadores con las ventajas que ello conlleva en materia de mantenimiento.

Dependiendo de la forma de trabajo o bien del producto a transportar incorporan bandas articuladas modulares de Acetal, Polipropileno o Polietileno y con acabados varios en materia de accesorios como guías laterales, superficies adherentes para transporte inclinado, superficies antiadherentes para una buena acumulación del producto.

Para los procesos donde es necesario el paso del aire, secado o deshielo del producto se emplean bandas articuladas con diferentes grados de apertura.

Para las aplicaciones de transporte estándar suele utilizarse la banda articulada totalmente cerrada.





NIKAI SYSTEMS offers a wide range of plastic modular belt conveyors that can be adjusted to transport work pieces of any type of form and weight. The conveyors can also be adapted to fit into physical workspaces where the desired equipment needs to be installed.

These types of conveyors are typically used the following sectors: food, packaging, bottling, automobile, etc.

For the food sector, these modular belts must comply with FDA regulations.

Unlike regular fabric belt conveyors, for plastic modular conveyors the dragging of the belt is not realized by friction but rather the traction of the pinion. Thus the tensions of the belts are lower and the adjustments are much easier and quicker.

Pins are used to join the different modules that make up the modular belt with the advantage that they themselves continue the movement of the work pieces.

Depending on the work pieces to transport, polyoxymethylen (POM), polypropylene or polyethylene modular belts are available along with accessories such as lateral guides, surfaces adherents for sloping, or surfaces anti-adherents for correct product accumulation.

For the processes where airflow, drying or thawing of products is needed, modular belts can be used with different degrees of opening.

For standard transport applications, totally closed modular belts are used.



NT 500

Transportador de banda modular
Modular plastic belt conveyor

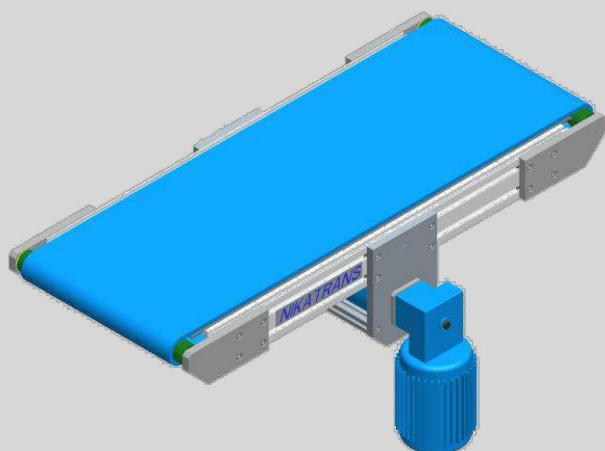

NT 510 10

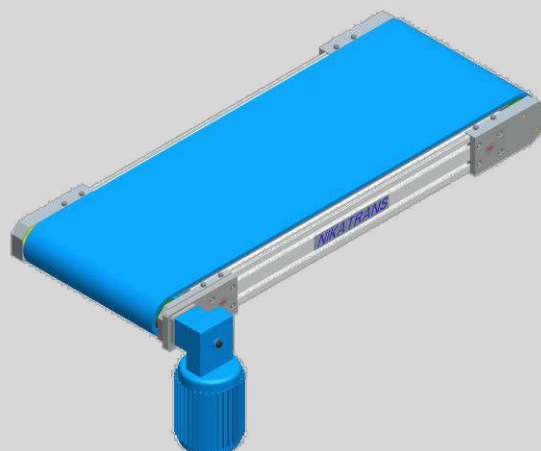

NT 510 20

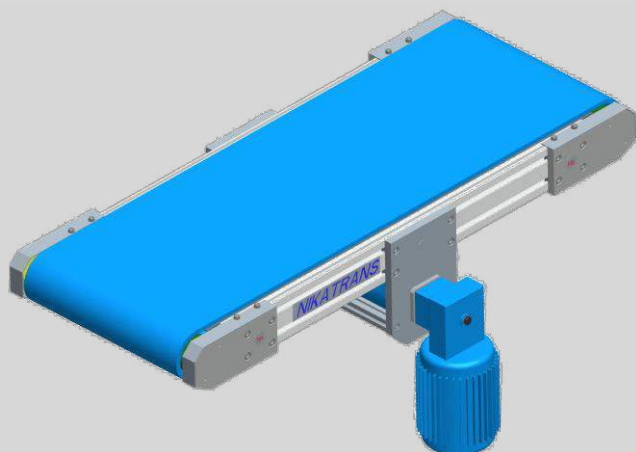

NT 510 25

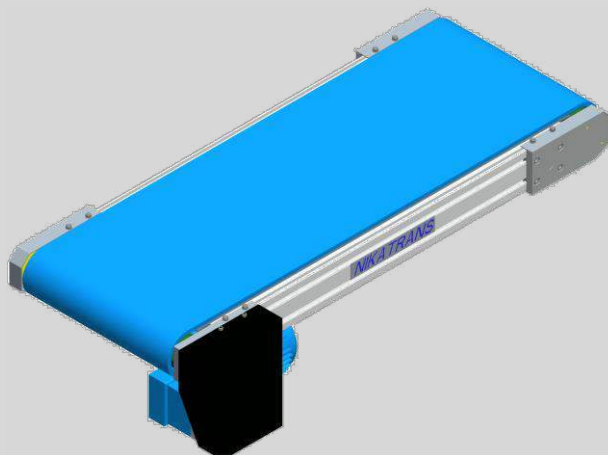

NT 510 30

NT 510 10

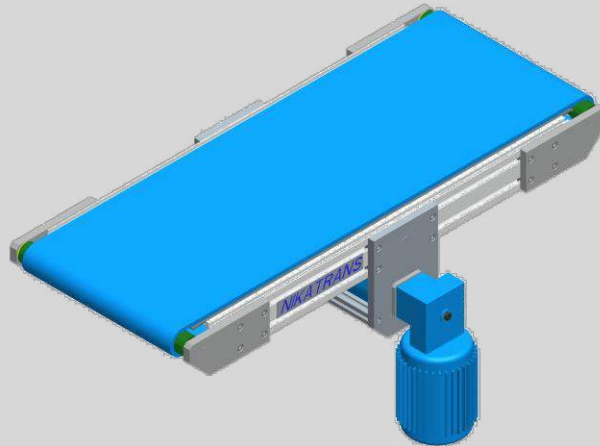

- Transportador de banda articulada con accionamiento por medio de motorreductor en posición central.
- Montaje del equipo motriz en cualquier punto a lo largo del transportador.
- Avance reversible del transportador.
- Chasis construido con perfil de aluminio extrusionado.
- Rodillos de apoyo de banda en ramal de retorno en tubo de aluminio de Ø50mm anodizado.
- Placas de amarre de los tambores en duraluminio anodizado.
- Tambor motriz de eje cuadrado de 40 mm en acero zincado.
- Piñones de arrastre de banda articulada de poliamida.
- Diámetro exterior de la banda engranada en los tambores de 60 mm.
- Rodamiento a bolas con engrase de por vida.
- Lecho de apoyo de tela en chapa de acero galvanizada o acero inoxidable.



- Modular belt conveyor driven by gear motor in central position.
- Drive unit can be assembled on any point along the conveyor.
- Conveyor can be put in reverse mode.
- Chassis constructed with extruded aluminium profile.
- Support rollers for the modular belt conveyor in unpainted anodised aluminium tube of Ø50mm.
- Drum flanges of unpainted anodised duraluminium.
- Drive drum has 40 mm zinc-plated steel square axle.
- Return drums have 25mm zinc-plated steel square axle.
- Pinions to drive the modular belt made of polyamide.
- Outside diameter of the belt engaged by 60 mm drums
- Ball bearings with greasing for life.
- Galvanized or stainless steel bed supports available.

NT 500

Transportador de banda modular Modular plastic belt conveyor

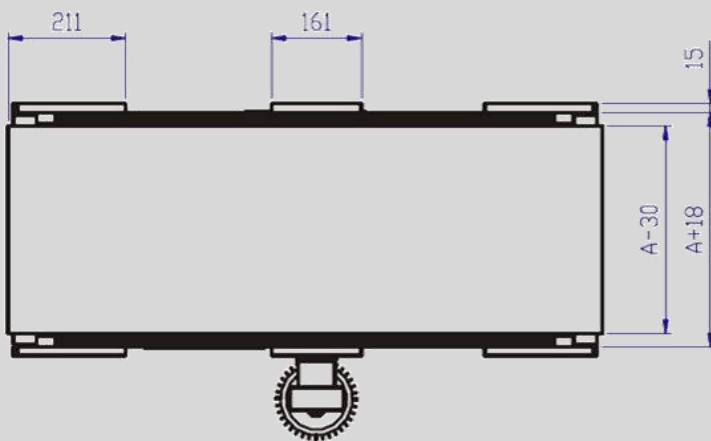
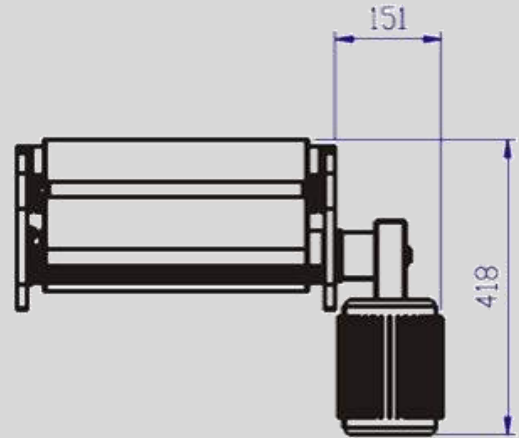
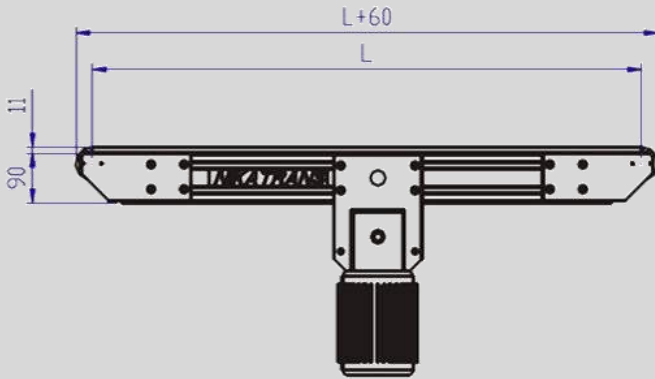



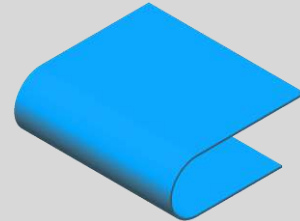

Tipo de banda articulada / Modular plastic types

	Kg / m ²	mm	 °C
PE	3,40	9,0	(-70) - (+65)
PP	3,30	9,0	(+5) - (+105)
LF	4,80	9,0	(-45) - (+90)



Información técnica / Technical information

P	mm	1" (25,4 mm)					
L	mm	max. 5000					
	v	3 x 220 / 3 x 380					
	m / min	5	7,5	10	13,5	20	30
	Kg	100	80	60	50	60	60
	Kw	0,12	0,12	0,12	0,12	0,18	0,25
	Nm	25	18	15	12	16	16

NT 510 20

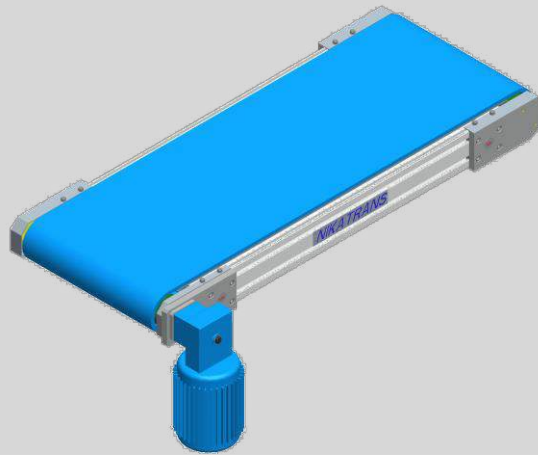

- Transportador de banda articulada con accionamiento por medio de motorreductor en posición extremo.
- Chasis construido con perfil de aluminio extrusionado.
- Rodillos de apoyo de banda en ramal de retorno en tubo de aluminio de Ø50mm anodizado.
- Placas de amarre de los tambores en duraluminio anodizado.
- Tambor motriz de eje cuadrado de 40 mm en acero zincado.
- Piñones de arrastre de banda articulada de poliamida.
- Diámetro exterior de la banda engranada en los tambores de 100 mm.
- Rodamiento a bolas con engrase de por vida.
- Lecho de apoyo de tela en chapa de acero galvanizada o acero inoxidable.



- Modular belt conveyor driven by gear motor at end.
- Chassis constructed with extruded aluminium profile.
- Support rollers for the modular belt conveyor in unpainted anodised aluminium tube of Ø50mm.
- Drum flanges of unpainted anodised duraluminium.
- Drive drum has 40 mm zinc-plated steel square axle.
- Return drums have 25mm zinc-plated steel square axle.
- Pinions to drive the modular belt made of polyamide.
- Outside diameter of the belt engaged by 100 mm drums.
- Ball bearings with greasing for life.
- Galvanized or stainless steel bed supports available.

NT 500

Transportador de banda modular Modular plastic belt conveyor

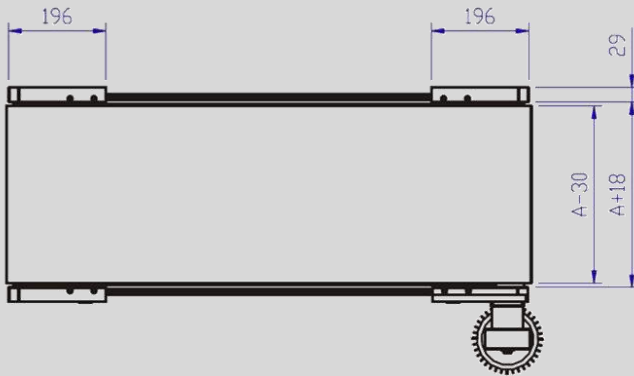
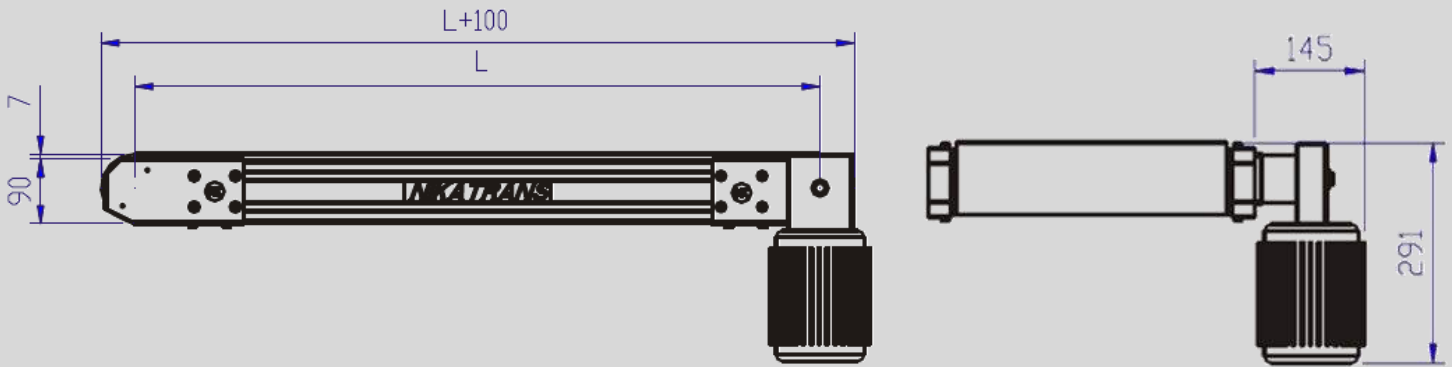

Tipo de banda articulada / Modular plastic types

	Kg / m ²	mm	°C
PE	3,40	9,0	(-70) - (+65)
PP	3,30	9,0	(+5) - (+105)
LF	4,80	9,0	(-45) - (+90)

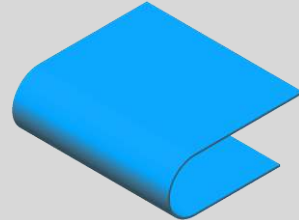

Información técnica / Technical information

P	mm	1" (25,4 mm)				
L	mm	max. 5000				
⚠	V	3 x 220 / 3 x 380				
➡	m / min	7,5	10	13,5	20	30
⚖	Kg	80	60	50	60	60
⚡	Kw	0,12	0,12	0,12	0,18	0,25
	Nm	18	15	12	16	16

NT 510 25

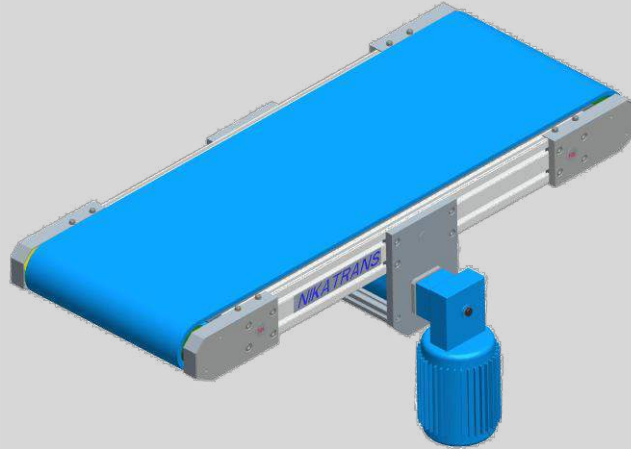

- Transportador de banda articulada con accionamiento por medio de motorreductor en posición central.
- Montaje del equipo motriz en cualquier punto a lo largo del transportador.
- Avance reversible del transportador.
- Chasis construido con perfil de aluminio extrusionado.
- Rodillos de apoyo de banda en ramal de retorno en tubo de aluminio de Ø50mm anodizado.
- Placas de amarre de los tambores en duraluminio anodizado.
- Tambor motriz de eje cuadrado de 40 mm en acero zincado.
- Piñones de arrastre de banda articulada de poliamida.
- Diámetro exterior de la banda engranada en los tambores de 100 mm.
- Rodamiento a bolas con engrase de por vida.
- Lecho de apoyo de tela en chapa de acero galvanizada o acero inoxidable.



- Modular belt conveyor driven by gear motor in central position.
- Drive unit can be assembled on any point along the conveyor.
- Conveyor can be put in reverse mode.
- Chassis constructed with extruded aluminium profile.
- Support rollers for the modular belt conveyor in unpainted anodised aluminium tube of Ø50mm.
- Drum flanges of unpainted anodised duraluminium.
- Drive drum has 40 mm zinc-plated steel square axle.
- Pinions to drive the modular belt made of polyamide.
- Outside diameter of the belt engaged by 100 mm drums.
- Ball bearings with greasing for life.
- Galvanized or stainless steel bed supports available.

NT 500

Transportador de banda modular Modular plastic belt conveyor

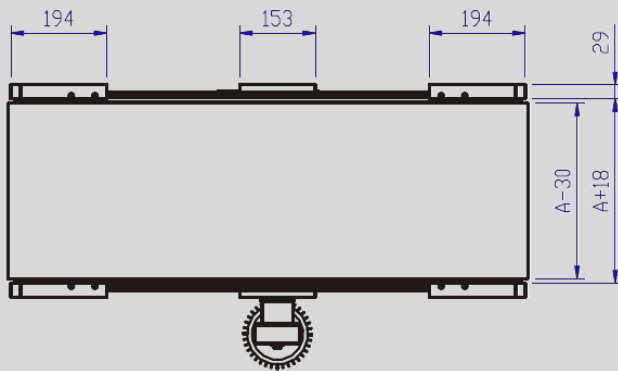
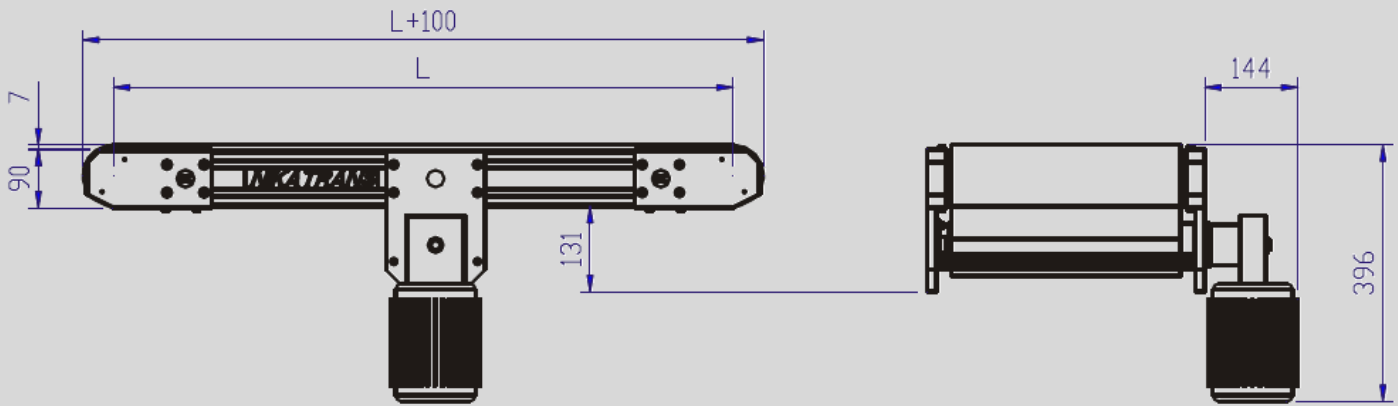

Tipo de banda articulada / Modular plastic types

	Kg / m ²	mm	°C
PE	3,40	9,0	(-70) - (+65)
PP	3,30	9,0	(+5) - (+105)
LF	4,80	9,0	(-45) - (+90)

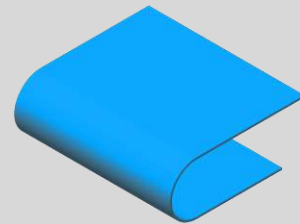

Información técnica / Technical information

P	mm	1" (25,4 mm)					
L	mm	max. 5000					
⚠	v	3 x 220 / 3 x 380					
➡	m / min	5	7,5	10	13,5	20	30
⚖	Kg	100	80	60	50	60	60
⚡	Kw	0,12	0,12	0,12	0,12	0,18	0,25
	Nm	25	18	15	12	16	16

NT 510 30

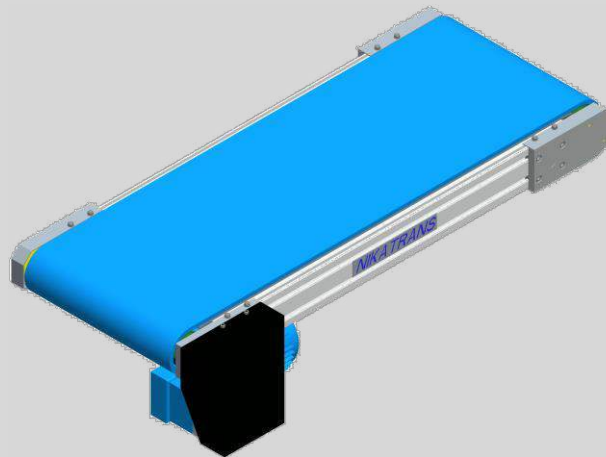

- Transportador de banda articulada con accionamiento indirecto por medio de motorreductor en posición inferior extremo.
- Transmisión por medio de cadena y piñones de ½".
- Protección de transmisión de chapa de acero pintada.
- Chasis construido con perfil de aluminio extrusionado.
- Rodillos de apoyo de banda en ramal de retorno en tubo de aluminio de Ø50mm anodizado.
- Placas de amarre de los tambores en duraluminio anodizado.
- Tambor motriz de eje cuadrado de 40 mm en acero zincado.
- Piñones de arrastre de banda articulada de poliamida.
- Diámetro exterior de la banda engranada en los tambores de 100 mm.
- Rodamiento a bolas con engrase de por vida.
- Lecho de apoyo de tela en chapa de acero galvanizada o acero inoxidable.



- Modular belt conveyor driven indirectly by gear motor in low position located at end.
- Transmission generated by chain and ½" pinion.
- Painted sheet steel protection for transmission.
- Chassis constructed with extruded aluminium profile.
- Support rollers for the modular belt conveyor in unpainted anodised aluminium tube of Ø50mm.
- Drum flanges of unpainted anodised duraluminium.
- Drive drum has 40 mm zinc-plated steel square axle.
- Return drums have 25mm zinc-plated steel square axle.
- Pinions to drive the modular belt made of polyamide.
- Outside diameter of the belt engaged by 100 mm drums.
- Ball bearings with greasing for life.
- Galvanized or stainless steel bed supports available.

NT 500

Transportador de banda modular Modular plastic belt conveyor

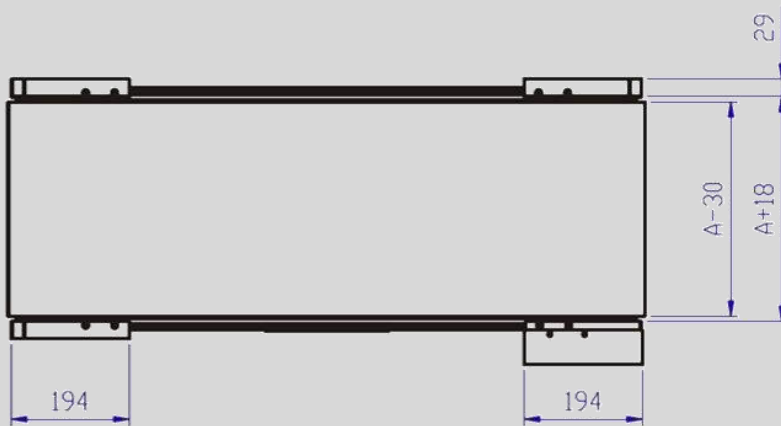
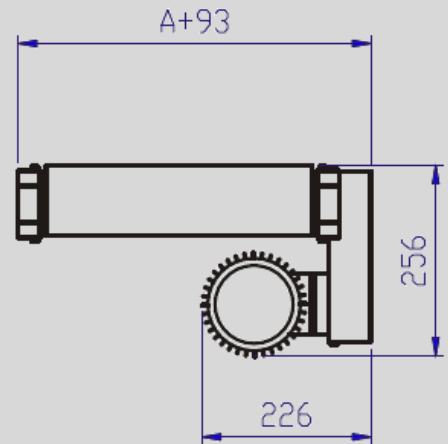
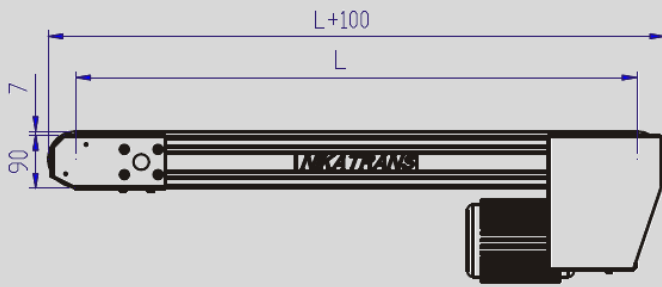

Tipo de banda articulada / Modular plastic types

	Kg / m ²	mm	°C
PE	3,40	9,0	(-70) - (+65)
PP	3,30	9,0	(+5) - (+105)
LF	4,80	9,0	(-45) - (+90)

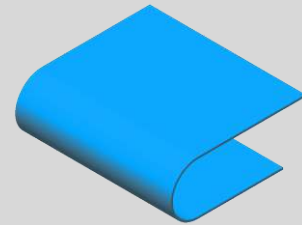

Información técnica / Technical information

P	mm	1" (25,4 mm)					
L	mm	max. 5000					
!	V	3 x 220 / 3 x 380					
→	m / min	5	7,5	10	13,5	20	30
⚖	Kg	80	120	140	110	140	150
⚡	Kw	0,12	0,18	0,25	0,25	0,37	0,55
	Nm	21	31	35	27	33	37

Tipos de guía / Type of guides

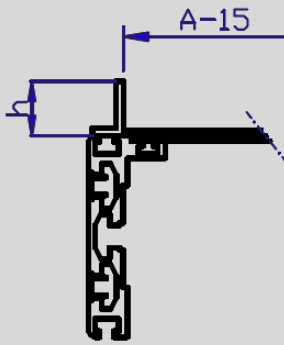

03

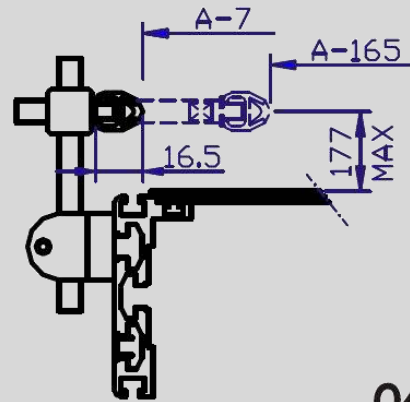

04

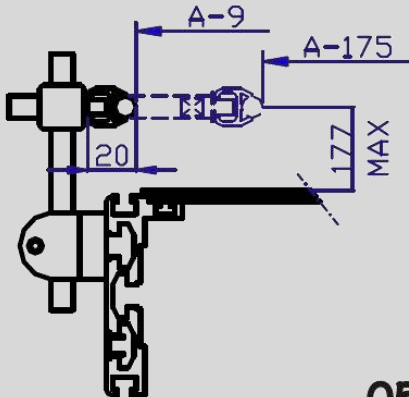

05

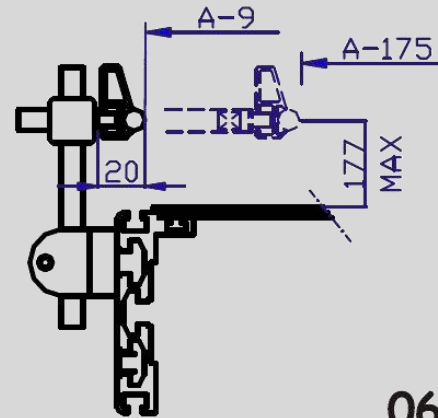

06