

# NT 700

Sistemas especiales

Special systems



## NT 700

### Sistemas especiales Special systems

 A continuación, les presentamos nuestra amplia gama de transportadores especiales basados en desarrollos estándar.

Un sin fin de equipos especiales para dar solución a sus necesidades de transporte.

 See next our wide range of special conveyors based on standard developments.

An endless number of special equipment to solve your transportation needs.

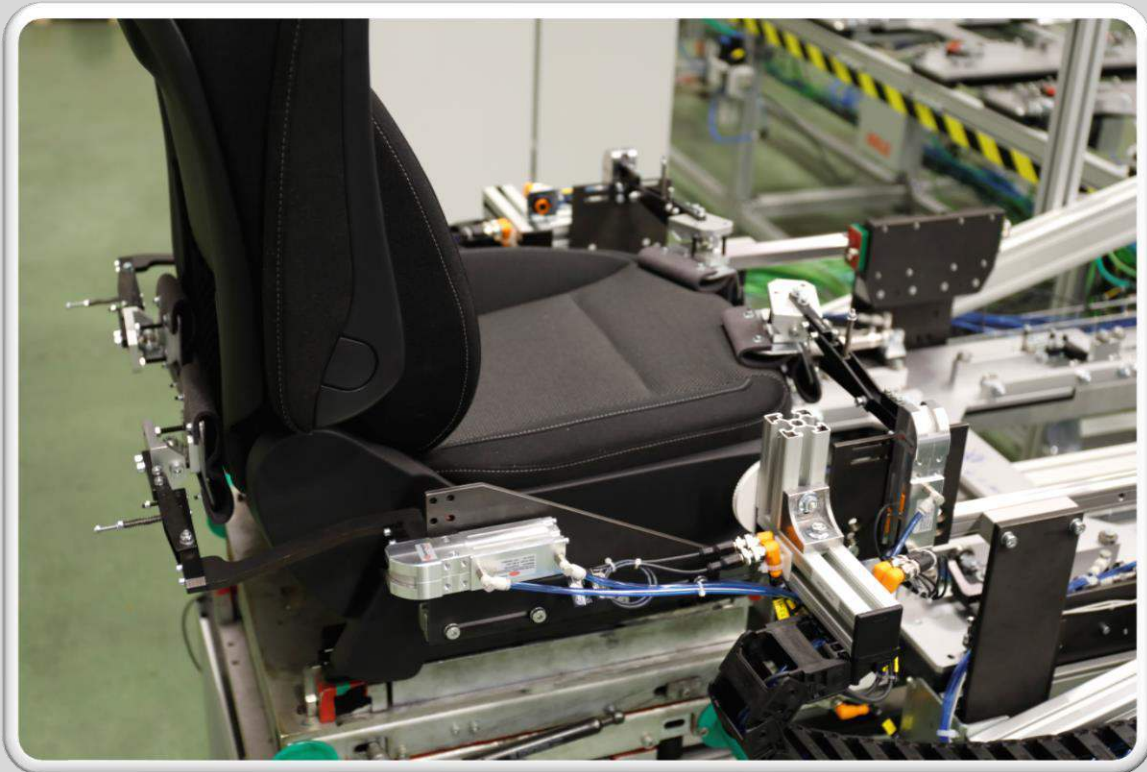
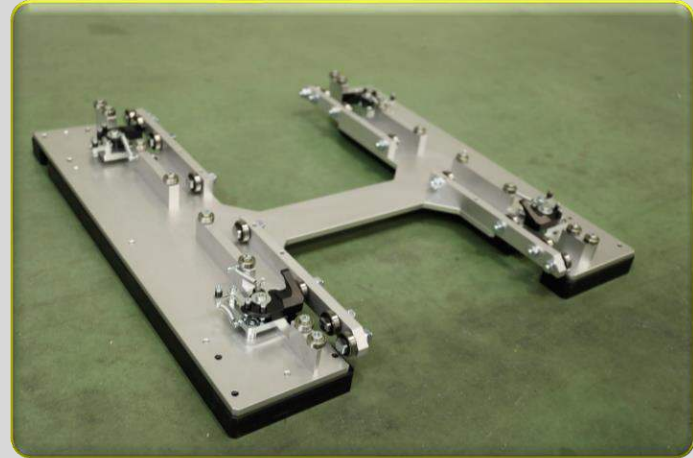

**NT 710**

Sistemas especiales para transportadores de banda.  
Special systems for belt conveyor

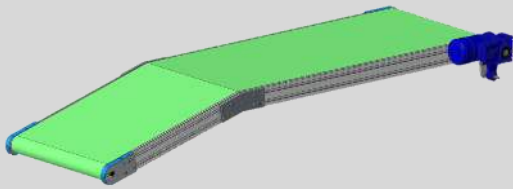

**NT 710 10**

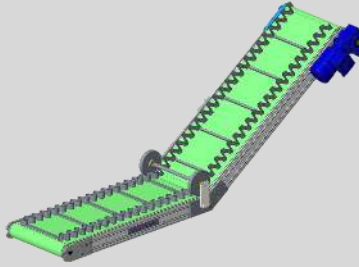

**NT 710 20**

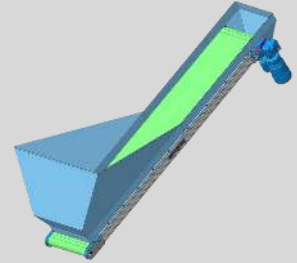

**NT 710 21**

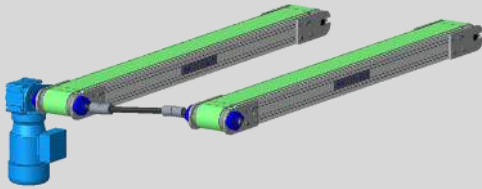

**NT 710 30**

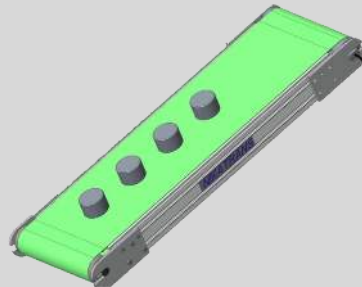

**NT 710 40**

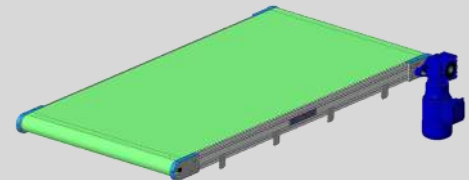

**NT 710 50**

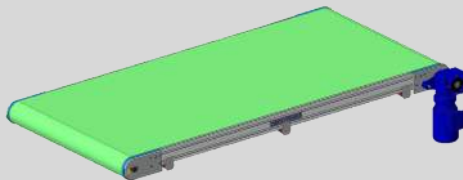

**NT 710 60**

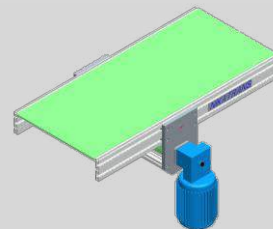

**NT 710 70**

**NT 730**

Sistemas especiales para transportadores de cadena articulada.

Special systems for slat chain conveyor.

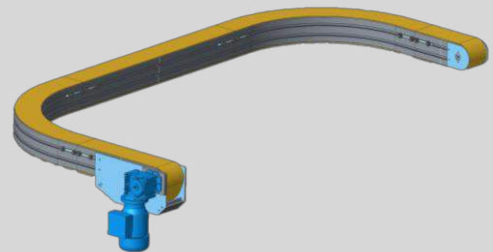
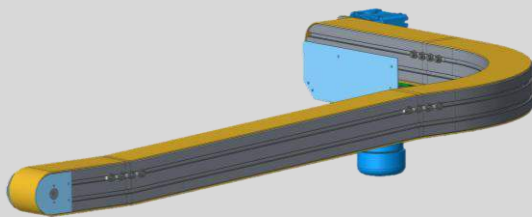
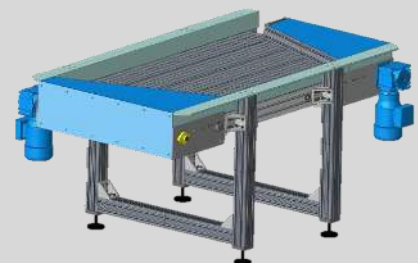
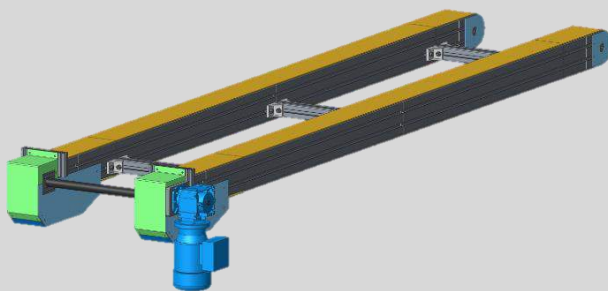
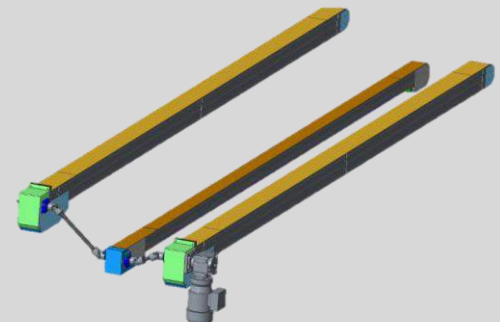
**NT 730 20****NT 730 30****NT 730 40****NT 730 50****NT 730 60****NT 730 65**

**NT 740**

Sistemas especiales para transportadores de correa dentada y cadena.  
Special systems for chain and timing belt conveyor.

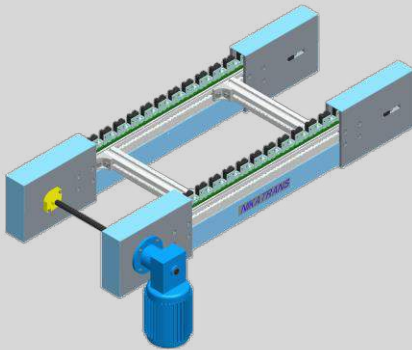
**NT 740 10****NT 750**

Sistemas especiales para transportadores de banda articulada  
Special systems for plastic modular belt conveyor.

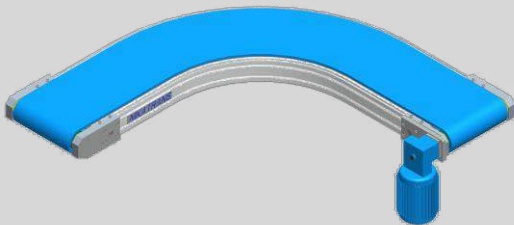
**NT 750 10**

**NT 760**

Sistemas especiales para accesorios.  
Special systems for Accesories.

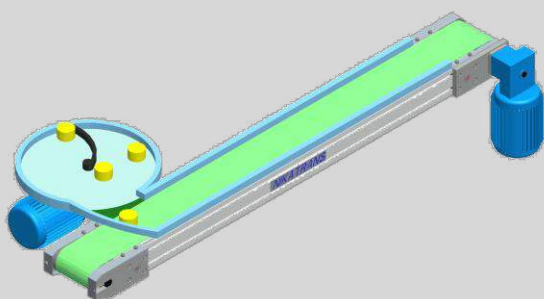

**NT 760 10**

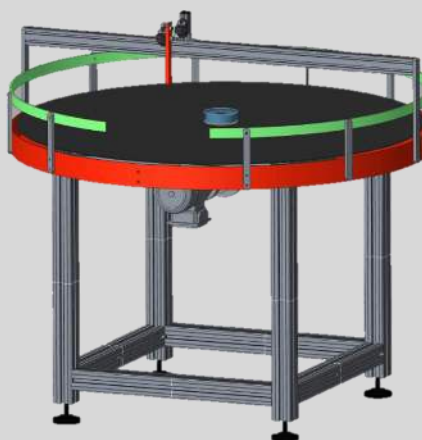
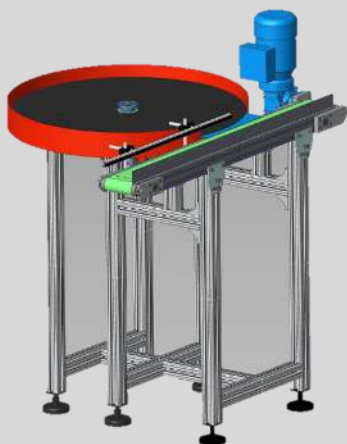

## NT 710 10

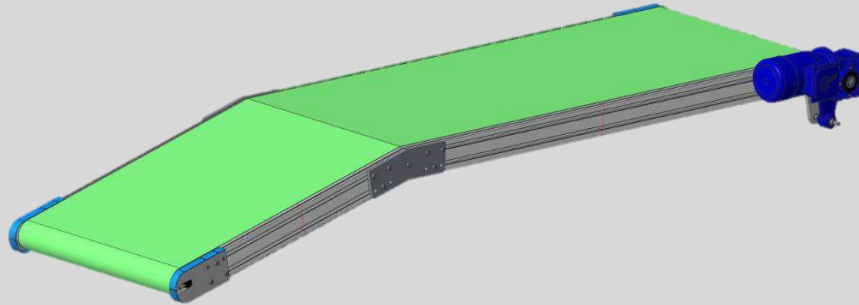

- Transportador de banda con inflexión y con accionamiento por medio de motorreductor en extremo.
- Chasis construido en perfil de aluminio.
- Rodillos de apoyo de tela en ramal de retorno en tubo de aluminio de Ø50 mm anodizado.
- Placas de amarre de los tambores en duraluminio anodizado.
- Tambores motriz y reenvío Ø80 mm con camisa de aluminio y eje de acero pavonado.
- Rodamientos a bolas con engrase de por vida.
- Lecho de apoyo de tela en chapa de acero.



- Belt conveyor with inflexión driven by gear motor located at end.
- Extruded aluminium profile frame.
- Ø50 mm unpainted anodised aluminium tube belt support rollers.
- Unpainted anodised duraluminium drum flanges.
- Ø80 mm drive and return drums covered in aluminium and blue steel shaft.
- Ball bearings with greasing for life.
- Galvanized or stainless sheet steel bed support for belt.

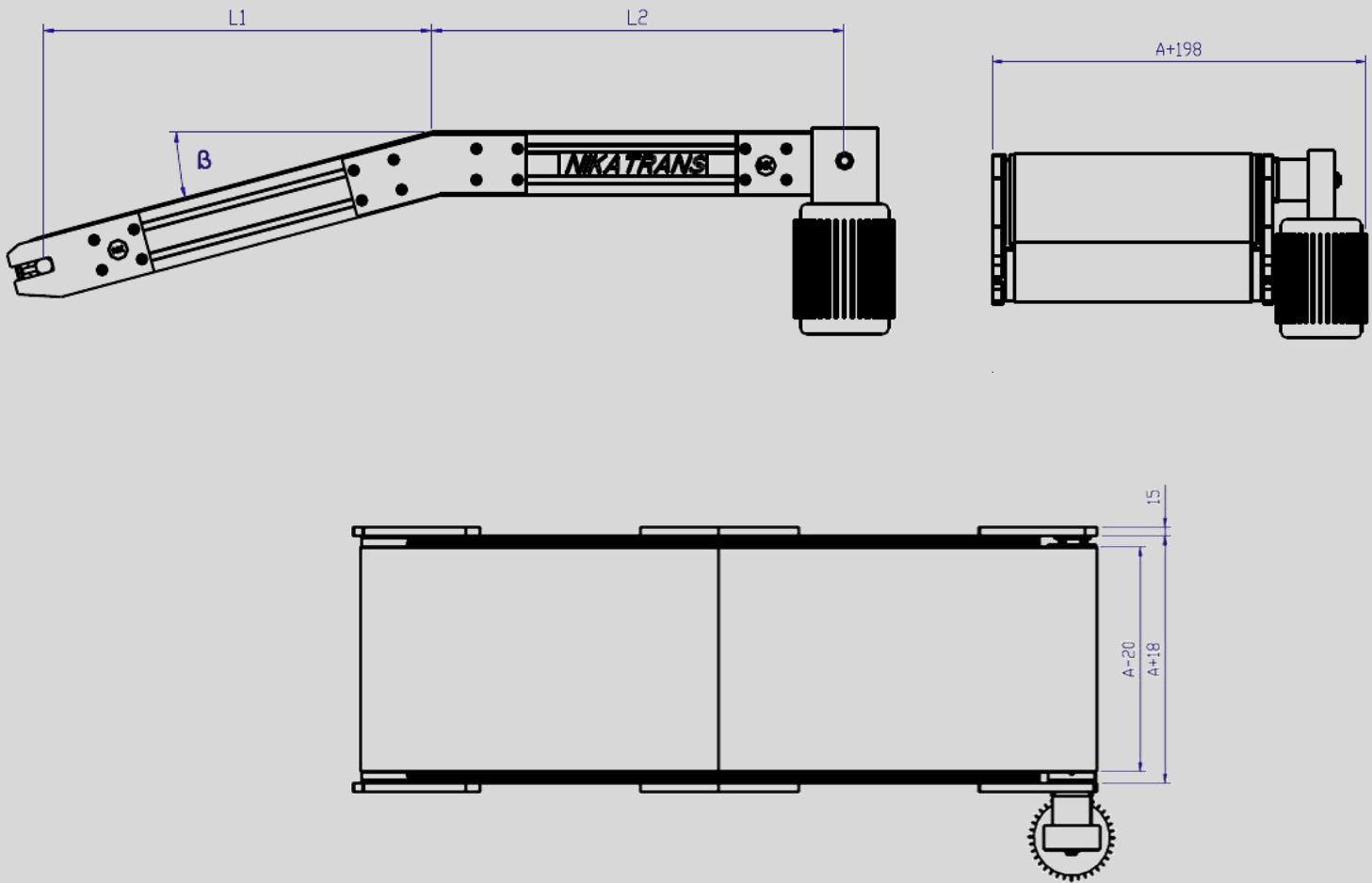

Información técnica / Technical information

A	mm	250 - 800						
L	mm	max. 5.000						
	V	3 x 220 / 3 x 380						
	m / min	3	5	7,5	10	13,5	20	30
	Kg	160	100	120	140	110	140	100
	Kw	0,12	0,12	0,18	0,25	0,25	0,37	0,37
	Nm	54	25	31	35	27	33	25
	°C	(-10) - (+80)						



## NT 710 20

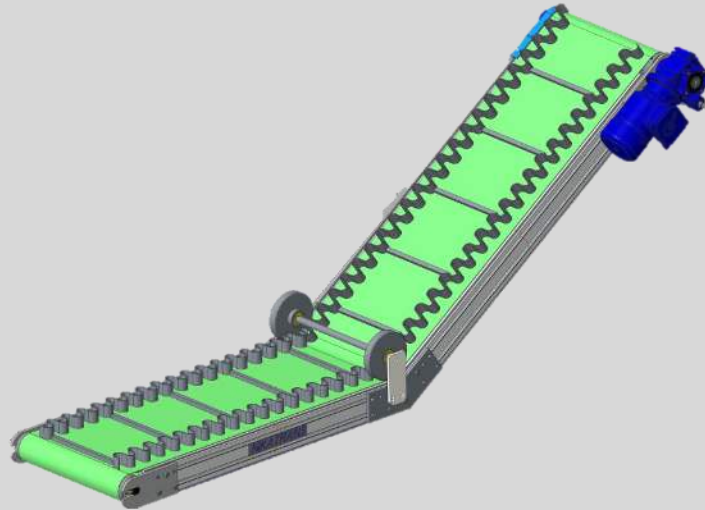

- Transportador de banda con inflexión ascendente y con accionamiento por medio de motorreductor en extremo.
- Chasis construido en perfil de aluminio.
- Rodillos de apoyo de tela en ramal de retorno en tubo de aluminio de Ø50 mm anodizado.
- Placas de amarre de los tambores en duraluminio anodizado.
- Tambores motriz y reenvío Ø80 mm con camisa de aluminio y eje de acero pavonado.
- Rodamientos a bolas con engrase de por vida.
- Lecho de apoyo de tela en chapa de acero.



- Ascending inclined belt conveyor driven by gear motor located at end.
- Extruded aluminium profile frame.
- Ø50 mm unpainted anodised aluminium tube belt support rollers.
- Unpainted anodised duraluminium drum flanges.
- Ø80 mm drive and return drums covered in aluminium and blue steel shaft.
- Ball bearings with greasing for life.
- Galvanized or stainless sheet steel bed support for belt.

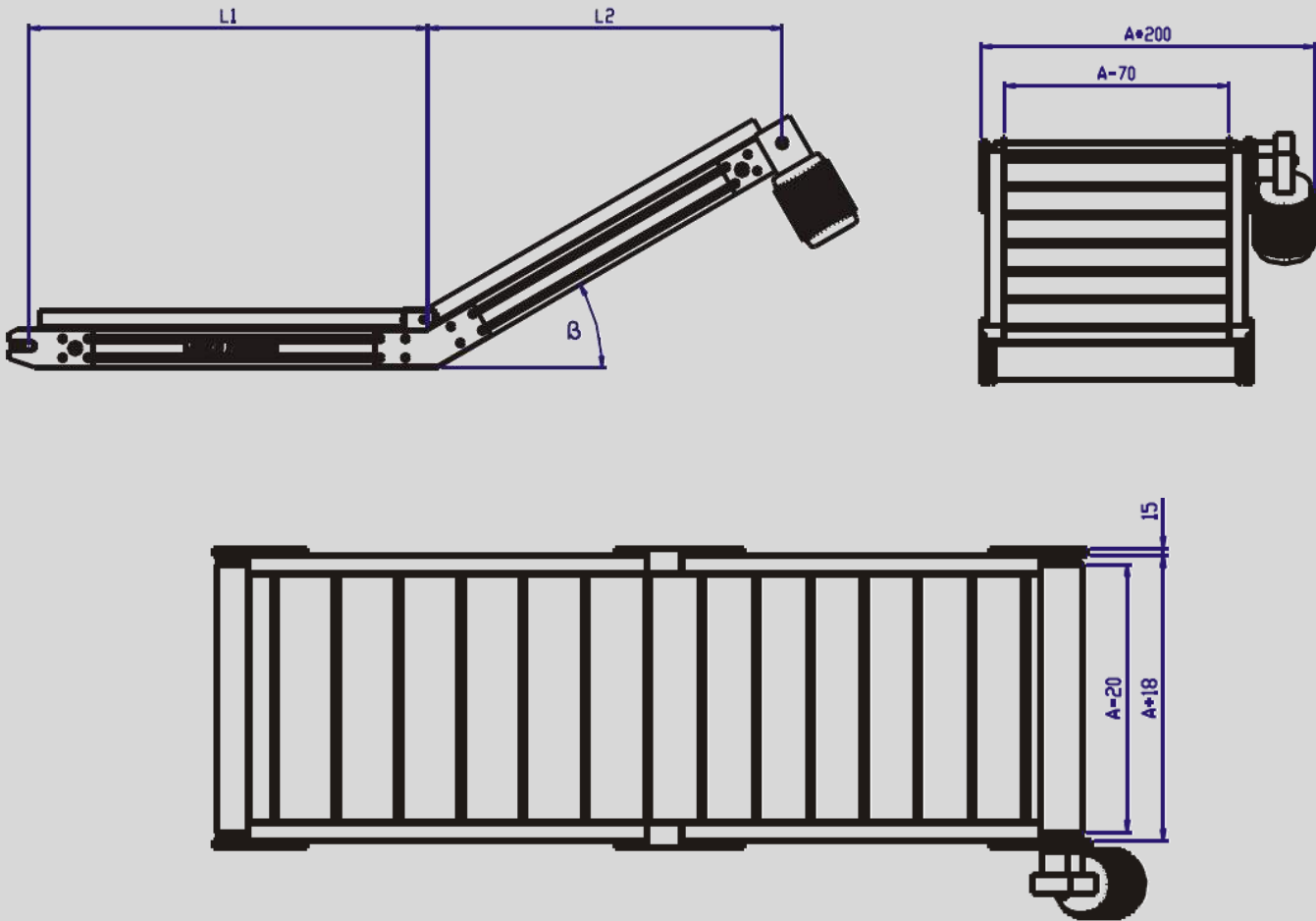

Información técnica / Technical information

A	mm	250 - 800						
L	mm	max. 5.000						
	V	3 x 220 / 3 x 380						
	m / min	3	5	7,5	10	13,5	20	30
	Kg	160	100	120	140	110	140	100
	Kw	0,12	0,12	0,18	0,25	0,25	0,37	0,37
	Nm	54	25	31	35	27	33	25
	°C	(-10) - (+80)						

## NT 710 21

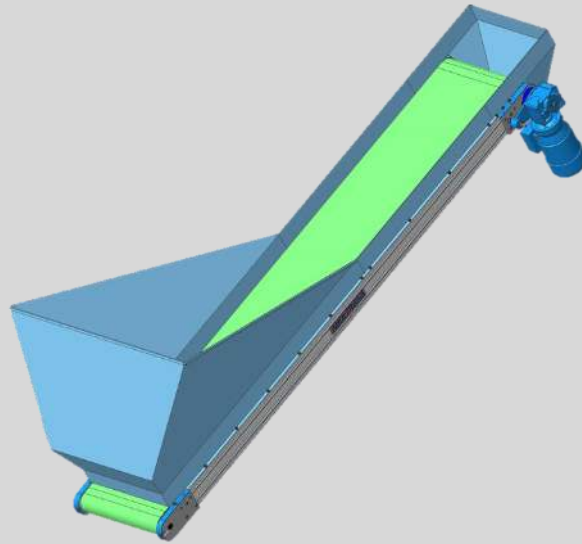

- Transportador de banda con inclinación ascendente y con accionamiento por medio de motorreductor en extremo.
- Chasis construido en perfil de aluminio.
- Rodillos de apoyo de tela en ramal de retorno en tubo de aluminio de Ø50 mm anodizado.
- Placas de amarre de los tambores en duraluminio anodizado.
- Tambores motriz y reenvío Ø80 mm con camisa de aluminio y eje de acero pavonado.
- Rodamientos a bolas con engrase de por vida.
- Lecho de apoyo de tela en chapa de acero.



- Ascending inclined belt conveyor driven by gear motor located at end.
- Extruded aluminium profile frame.
- Ø50 mm unpainted anodised aluminium tube belt support rollers.
- Unpainted anodised duraluminium drum flanges.
- Ø80 mm drive and return drums covered in aluminium and blue steel shaft.
- Ball bearings with greasing for life.
- Galvanized or stainless sheet steel bed support for belt.

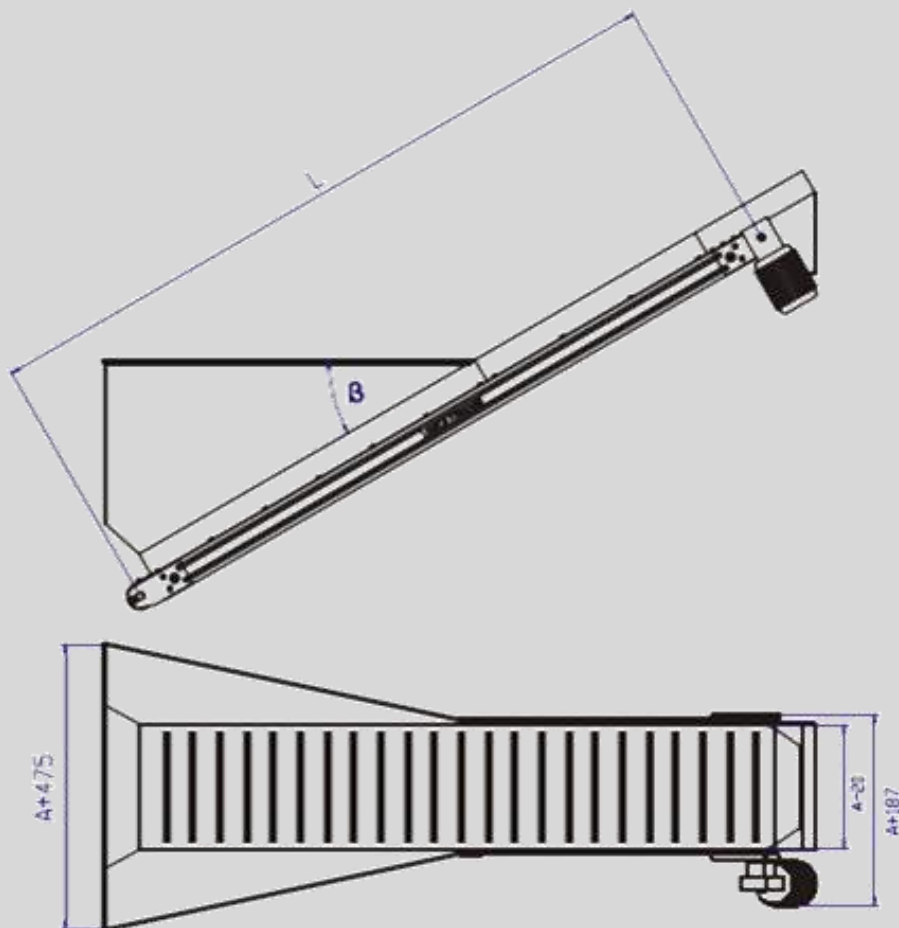

Información técnica / Technical information

A	mm	250 - 800						
L	mm	max. 5.000						
	V	3 x 220 / 3 x 380						
	m / min	3	5	7,5	10	13,5	20	30
	Kg	160	100	120	140	110	140	100
	Kw	0,12	0,12	0,18	0,25	0,25	0,37	0,37
	Nm	54	25	31	35	27	33	25
	°C	(-10) - (+80)						

## NT 710 30

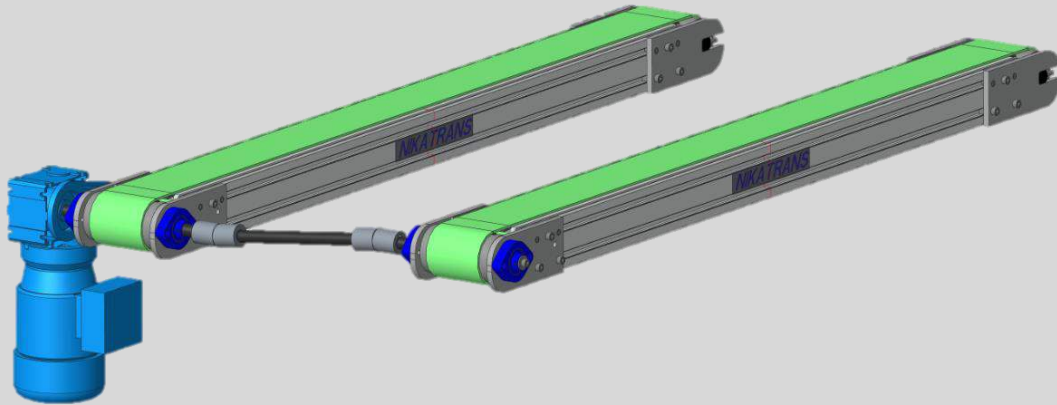

- Tandem de transportador de banda en paralelo y con accionamiento por medio de motorreductor en extremo.
- Chasis construido en perfil de aluminio.
- Rodillos de apoyo de tela en ramal de retorno en tubo de aluminio de Ø50 mm anodizado.
- Placas de amarre de los tambores en duraluminio anodizado.
- Tambores motriz y reenvío con camisa de aluminio y eje de acero pavonado.
- Rodamientos a bolas con engrase de por vida.
- Lecho de apoyo de tela en chapa de acero.



- Parallel belt conveyors in tandem driven by gear motor located at end.
- Extruded aluminium profile frame.
- Unpainted anodised aluminium tube belt support rollers.
- Unpainted anodised duraluminium drum flanges.
- Drive and return drums covered in aluminium and stainless steel shaft.
- Ball bearings with greasing for life.
- Galvanized or stainless sheet steel bed support for belt.

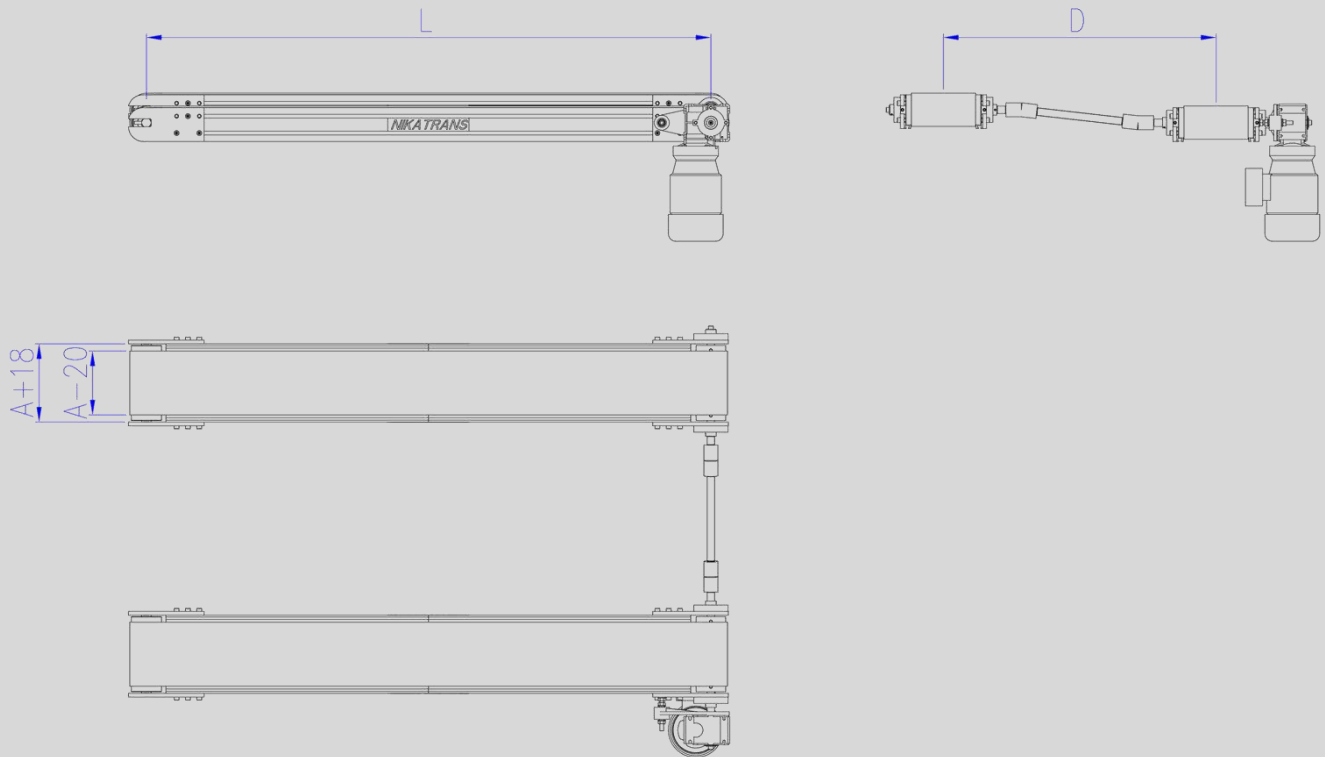

### Información técnica / Technical information

A	mm	250 - 800						
L	mm	max. 5000						
	V	3 x 220 / 3 x 380						
	m / min	3	5	7,5	10	14	20	30
	Kg	160	100	120	140	110	140	100
	Kw	0,12	0,12	0,18	0,25	0,25	0,37	0,37
	Nm	54	25	31	35	27	33	25
	°C	(-10) - (+80)						

## NT 710 40

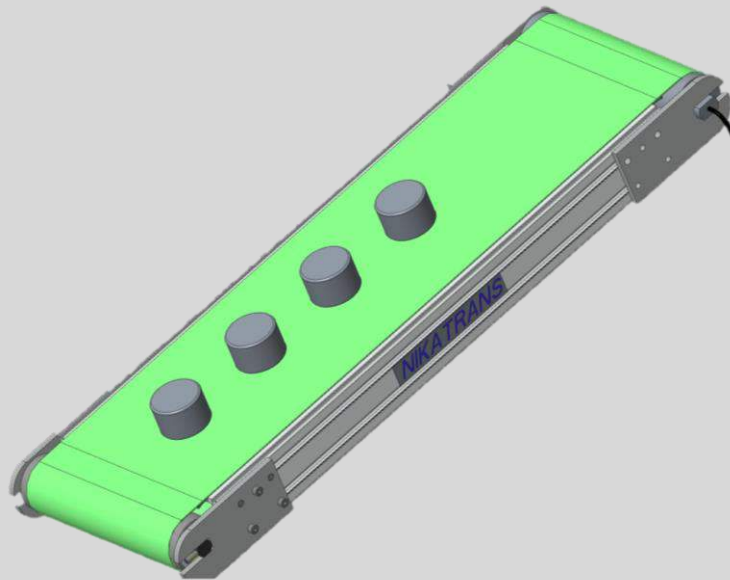

- Transportador de banda imantado con accionamiento por medio de mototambor extremo.
- Chasis construido en perfil de aluminio.
- Rodillos de apoyo de tela en ramal de retorno en tubo de aluminio anodizado.
- Placas de amarre de los tambores en duraluminio anodizado.
- Tambores reenvio con camisa de aluminio y eje de acero pavonado.
- Rodamientos a bolas con engrase de por vida.
- Lecho de apoyo de tela en chapa de acero.



- Magnetic belt conveyors driven by drum located at end.
- Extruded aluminium profile frame.
- Unpainted anodised aluminium tube belt support rollers.
- Unpainted anodised duraluminium drum flanges.
- Drive and return drums covered in aluminium and stainless steel shaft.
- Ball bearings with greasing for life.
- Stainless sheet steel bed support for belt.

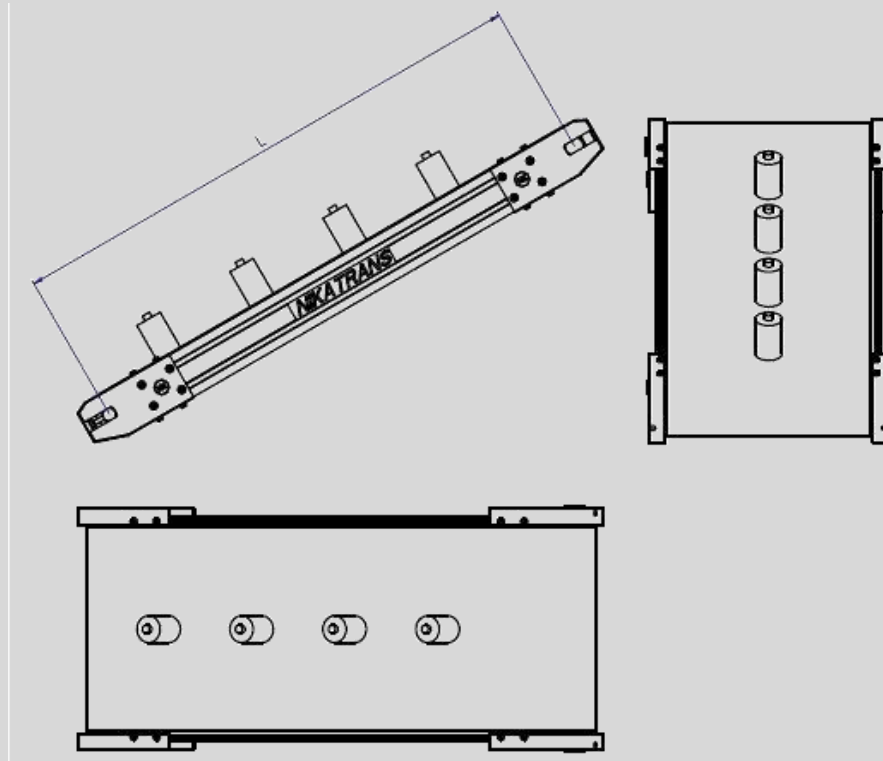

### Información técnica / Technical information

A	mm	300 - 950							
L	mm	max. 5000							
	V	3 x 220 / 3 x 380 / 2 x 220							
	m / min	4,8	7,2	9,6	13	16	36	43	53
	Kg	40	30	30	50	40	20	16	16
	Kw	0,075	0,075	0,085	0,085	0,085	0,085	0,085	0,085
	Nm	10,8	21,5	19,5	13,3	10,8	5,2	4,3	3,5
	°C	(+10) - (+40)							



## NT 710 50

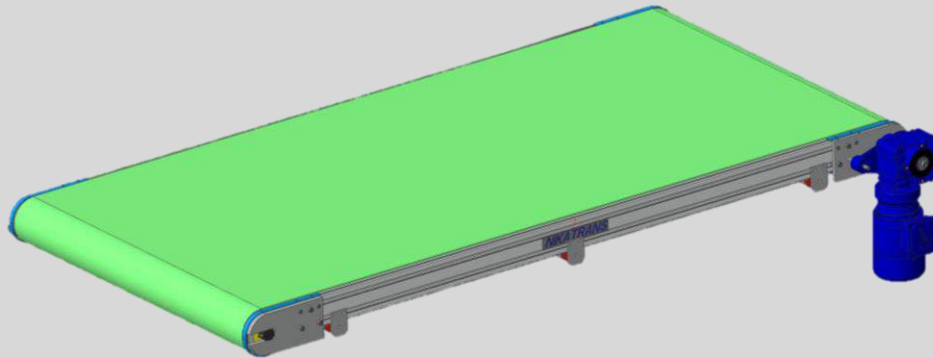

- Transportador de banda con guiado de tela central con accionamiento por medio de motorreductor en extremo.
- Chasis construido en perfil de aluminio.
- Rodillos de apoyo de tela en ramal de retorno en tubo de aluminio de Ø50 mm anodizado.
- Placas de amarre de los tambores en duraluminio anodizado.
- Tambores motriz y de reenvío Ø80 mm con camisa de aluminio y eje de acero pavonado.
- Rodamientos a bolas con engrase de por vida.
- Lecho de apoyo de tela en chapa de acero galvanizada o de acero inoxidable.



- Belt conveyor with belt fabric guide drive by gear motor located at end.
- Extruded aluminium profile frame.
- Ø50 mm unpainted anodised aluminium tube belt support rollers.
- Unpainted anodised duraluminium drum flanges.
- Ø80 mm return drum covered in aluminium and blue steel shaft.
- Ball bearings with greasing for life.
- Stainless sheet steel bed support for belt

# NT 700

Sistemas especiales  
Special systems

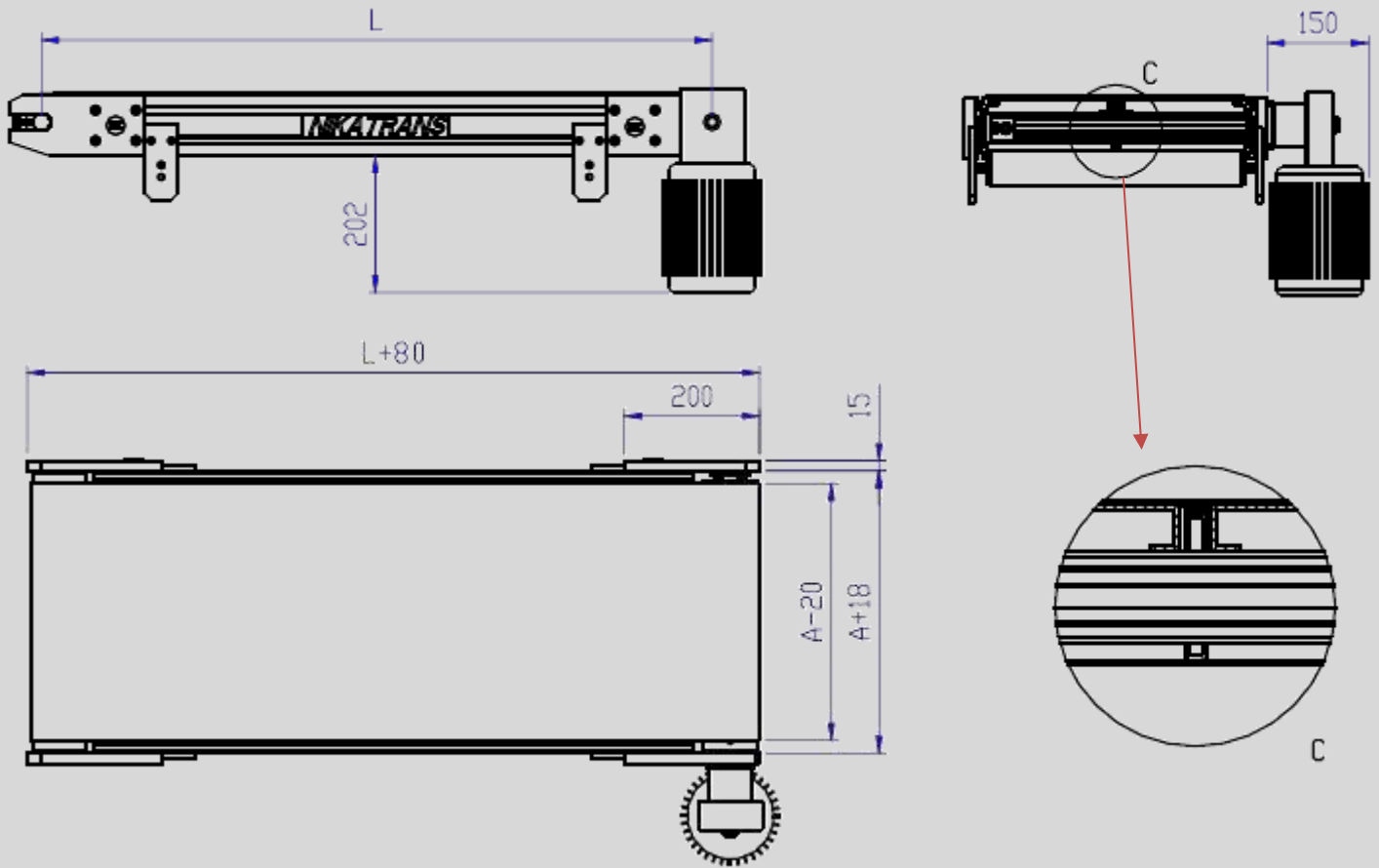

## Información técnica / Technical information

A	mm	250 - 620					
L	mm	max. 5.000					
	V	3 x 380					
	m / min	3,7	5,2	7,2	10	13,5	19
	Kg	70	85	100	100	100	85
	Kw	0,09	0,09	0,18	0,18	0,18	0,18
	Nm	12	14	18	18	17	16
	°C	(-10) - (+80)					

## NT 710 60

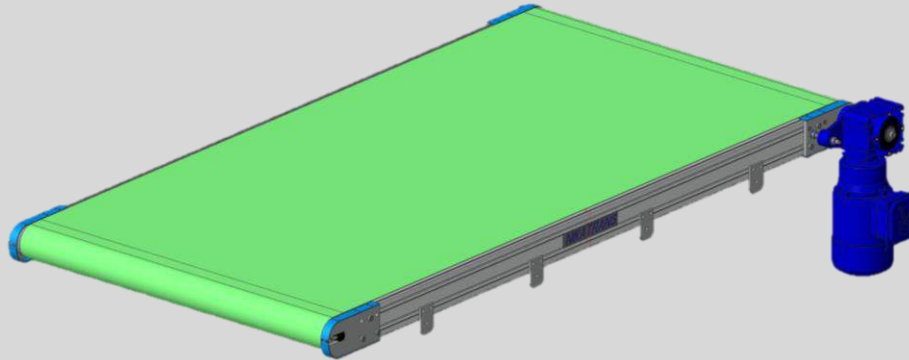

- Transportador de banda con accionamiento por medio de motorreductor en extremo.
- Chasis construido en perfil de aluminio.
- Rodillos de apoyo de tela en ramal de retorno en tubo de aluminio de Ø50 mm anodizado.
- Placas de amarre de los tambores en duraluminio anodizado.
- Tambores motriz y de reenvío Ø120 mm con camisa de aluminio y eje de acero pavonado.
- Rodamientos a bolas con engrase de por vida.
- Lecho de apoyo de tela en chapa de acero galvanizada o de acero inoxidable.



- Belt conveyor drive by gear motor located at end.
- Extruded aluminium profile frame.
- Ø50 mm unpainted anodised aluminium tube belt support rollers.
- Unpainted anodised duraluminium drum flanges.
- Ø120 mm return drum covered in aluminium and blue steel shaft.
- Ball bearings with greasing for life.
- Stainless sheet steel bed support for belt

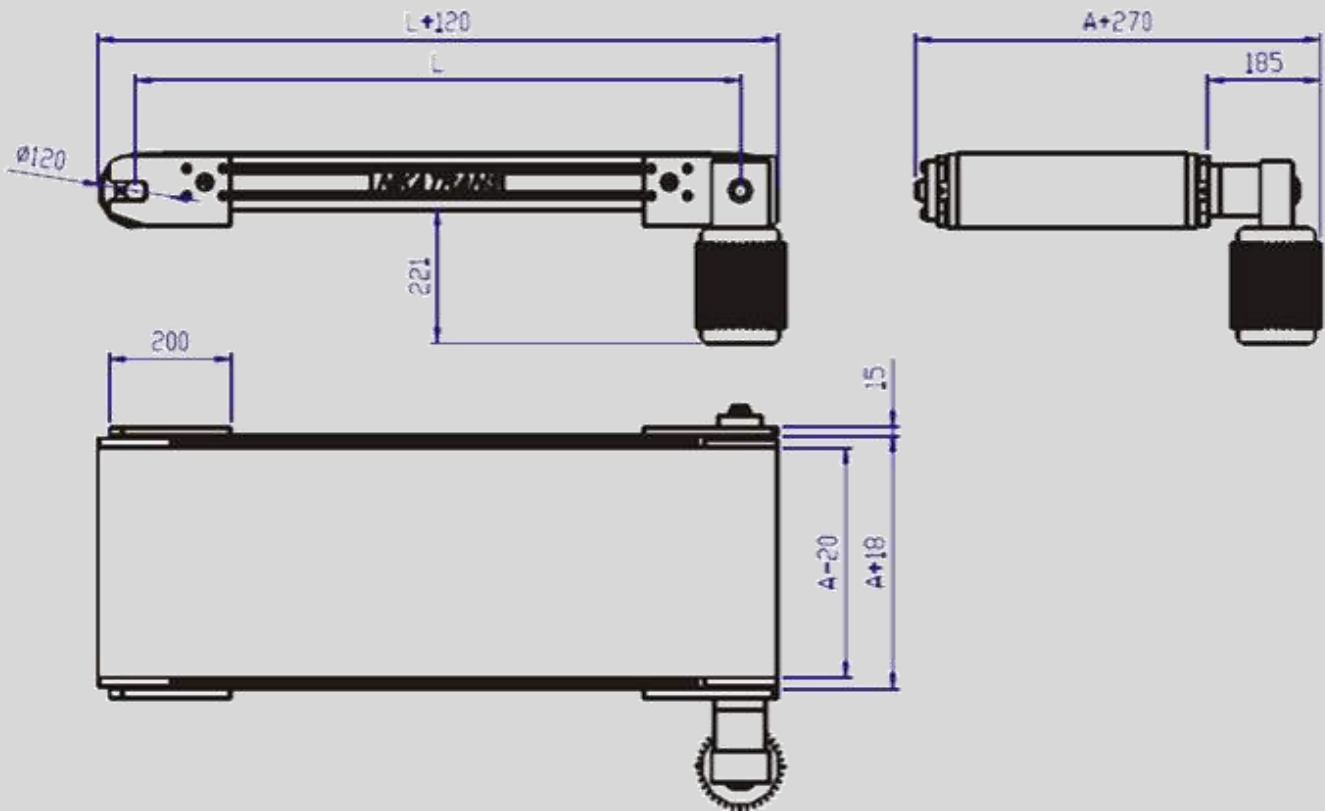

Información técnica / Technical information

A	mm	max. 1000					
L	mm	max. 10.000					
	V	3 x 380					
	m / min	10	15	20	30	40	50
	Kg	150	150	150	150	150	120
	Kw	0,18	0,18	0,25	0,37	0,37	0,37
	Nm	60	58	57	69	55	43
	°C	(-10) - (+80)					

## NT 710 70

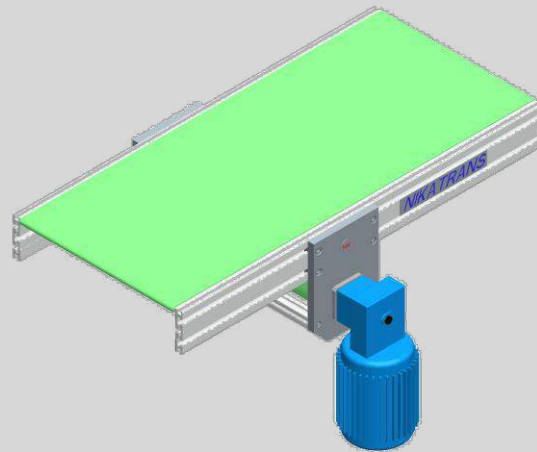

- Transportador de banda con accionamiento por medio de motorreductor en posición central.
- Montaje del equipo motriz en cualquier punto a lo largo del transportador.
- Avance reversible del transportador.
- Chasis construido en perfil de aluminio.
- Rodillos de apoyo de tela en ramal de retorno en tubo de aluminio de Ø50 mm anodizado.
- Placas de amarre de los tambores en duraluminio anodizado.
- Tambores motriz Ø80 mm con camisa de aluminio y eje de acero pavonado.
- Tambores de reenvío a modo de canto de cuchilla para el paso de piezas pequeñas dimensiones.
- Rodamientos a bolas con engrase de por vida.
- Lecho de apoyo de tela en chapa de acero galvanizada o de acero inoxidable.





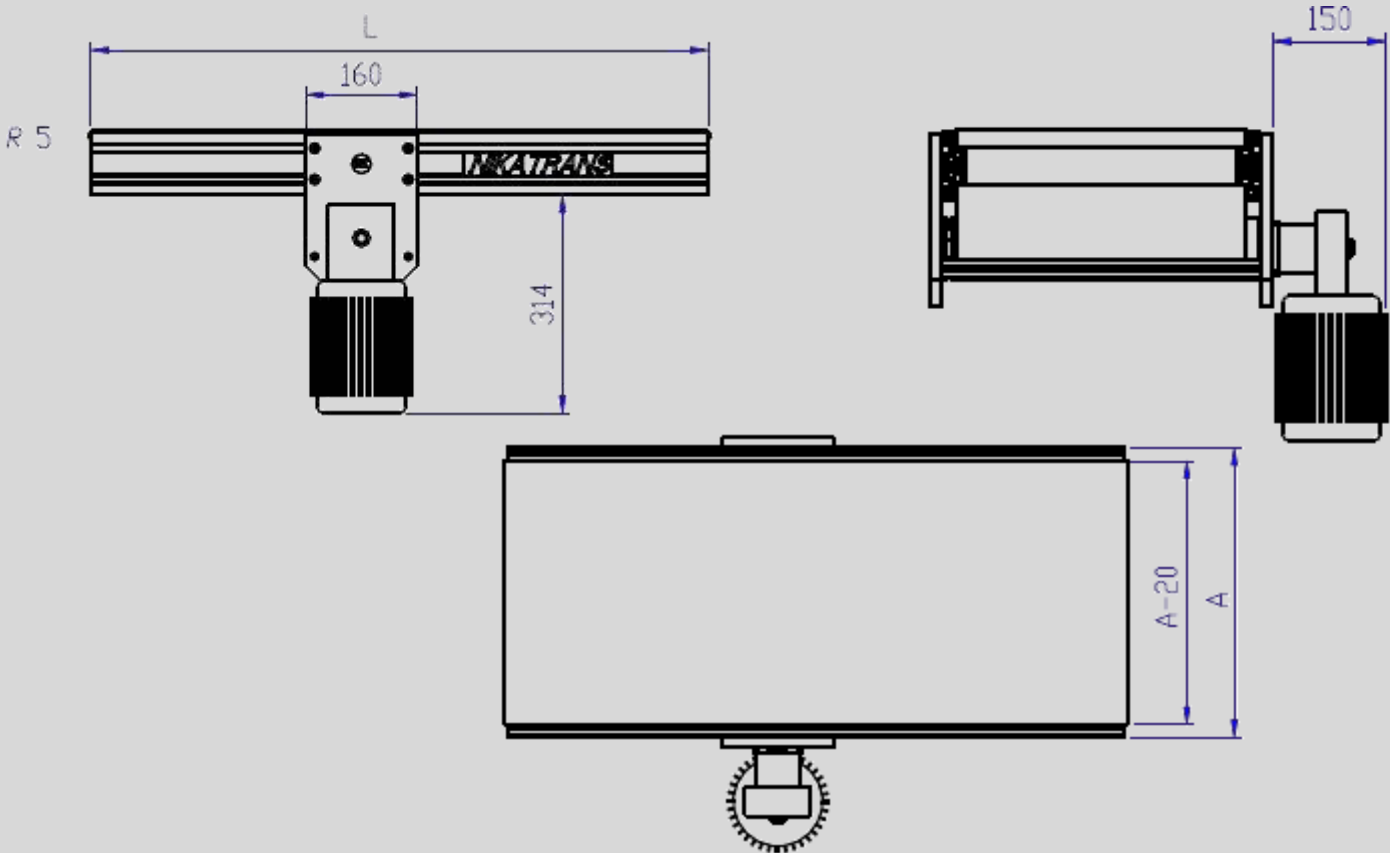

- Belt conveyor drive by gear motor in central position.
- Drive assembly can be mounted in any point along the conveyor.
- Possibility to put conveyor in reverse mode.
- Extruded aluminium profile frame.
- Ø50 mm unpainted anodised aluminium tube belt support rollers.
- Unpainted anodised duraluminium drum flanges.
- Ø80 mm drive and return drums covered in aluminium and blue steel shaft.
- Return drums replaced by special edge part allowing for the transfer of small pieces.
- Ball bearings with greasing for life.
- Galvanized or stainless sheet steel bed support for belt.

# NT 700

Sistemas especiales  
Special systems





## Información técnica / Technical information

A	mm	250 - 400					
L	mm	max. 5.000					
	V	3 x 380					
	m / min	3,7	5,2	7,2	10	13,5	19
	Kg	35	42,5	50	50	50	42,5
	Kw	0,18	0,18	0,36	0,36	0,36	0,36
	Nm	12	14	18	18	17	16
	°C	(-10) - (+80)					



## Tipos de banda / Belt types

### Bandas lisas / standard belts

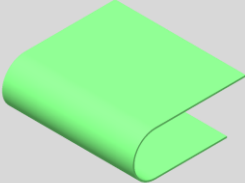
	Kg / m <sup>2</sup>	 mm
PVC	1,10	1,00
PU	1,10	1,00
FDA	0,90	0,80
	3,50	3,00



### Bandas con tacos / Belts with cleats

		b (mm)	h (mm)	a (mm)
	PVC	8	5	4,4
		10	6	5,6
	PU	10	50	
		10	50	

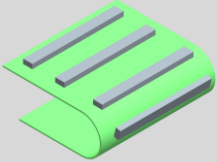

## NT 730 20





- Transportador de cadena articulada de ancho 114,3 mm con accionamiento por medio de motorreductor en posición central.
- Chasis en perfil de aluminio extrusionado de 120 x 113 mm
- Guía estándar de deslizamiento de la cadena:
  - PET (-40°C a +80°C)
  - Acero sulfinado para altas temperaturas (-70 a 430°C).
- Calidades de las cadenas articuladas:
  - Cadena de aleaciones de acero inoxidable ferrítico de alta calidad AISI 430 (-70°C a +430°C) magnético.
  - Cadena de aleaciones de acero inoxidable austénico de alta calidad AISI 304 (-70°C a +430°C) no magnético.
  - Cadena de aleaciones de acero de alta calidad tratado y templado con carbono (-70°C a +430°C), magnético.
- Placas de amarre del motorreductor en duraluminio anodizado.
- Eje, piñón motriz y reenvío de acero pavonado.
- Tensor de cadena en el reenvío.
- Rodamientos a bolas autolineables con engrase de por vida.
- Curvas standard: 90° y 180° - Radio: 500 mm. Posibilidad de curvas con diferentes radios y grados.
- Slat chain conveyor with width of 114,3 mm driven by central gear motor.





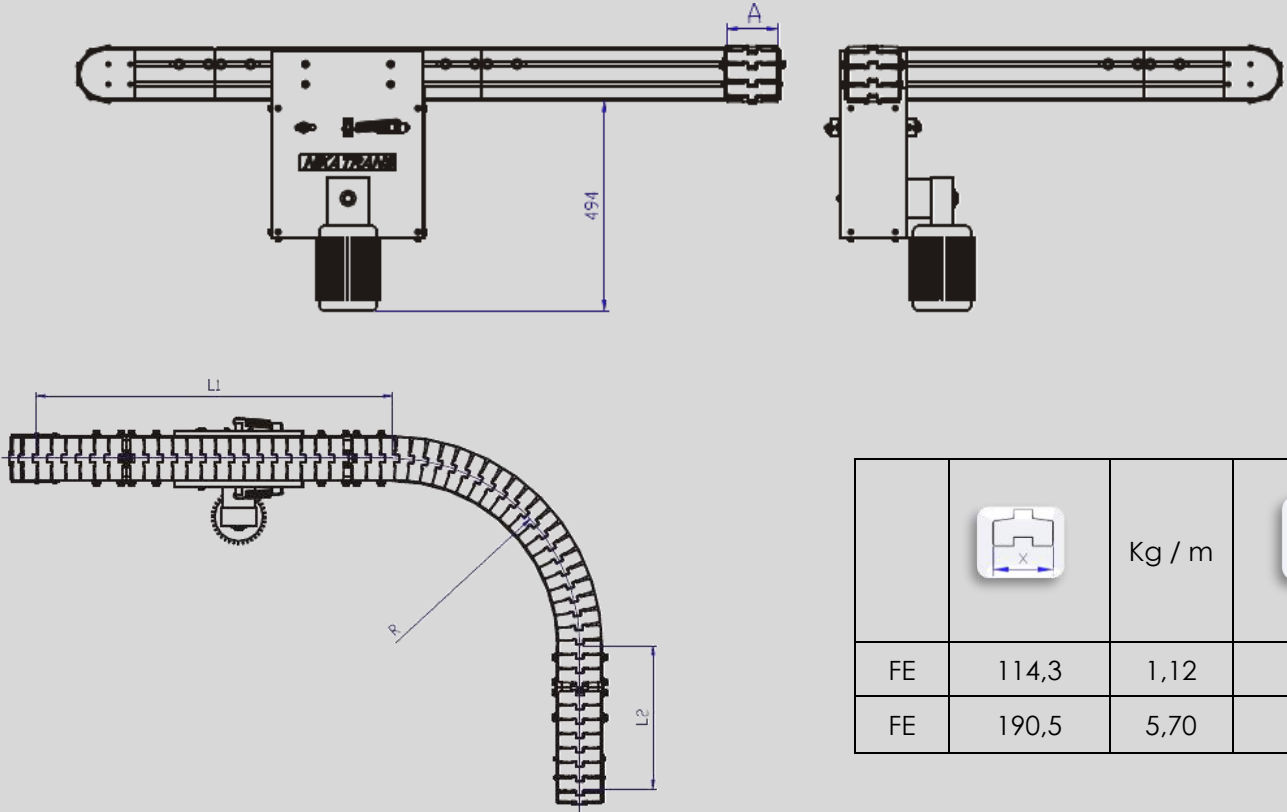

- Extruded 120 x 113 mm aluminium profile frame.
- Standard slide guide
  - PET (-40°C to +80°C)
  - Sulfinized steel for high temperatures (-40°C to +430°C)
- Qualities of the steel chains:
  - High quality ferritic stainless steel alloy chain AISI 430 (-70°C to +430°C) magnetic
  - High quality austenitic stainless steel alloy chain AISI 304 (-70°C to +430°C) non-magnetic
  - High quality treated and hardened carbon steel alloy chain (-70°C to +430°C) magnetic.
- Gear motor flanges of anodised duraluminium.
- Blue steel shaft, drive and return pinion.
- Chain tensor located at return end of conveyor.
- Auto-alignable bearings with greasing for life.
- Standard curves: 90° and 180° - Radius: 500 mm. Possibility curves with different radius and grades.

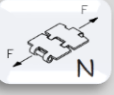



		Kg / m	
FE	114,3	1,12	2250
FE	190,5	5,70	2250

### Información técnica / Technical information

A	mm	120 / 200					
R	mm	500 / 750					
	V	3 x 380					
	m / min	3,7	5,2	7,2	10	13,5	19
	Kg	150	150	100	100	100	100
	Kw	0,12	0,12	0,18	0,25	0,25	0,37
	Nm	60	54	38	47	35	41
	°C	(-70) - (+430)					

## NT 730 30

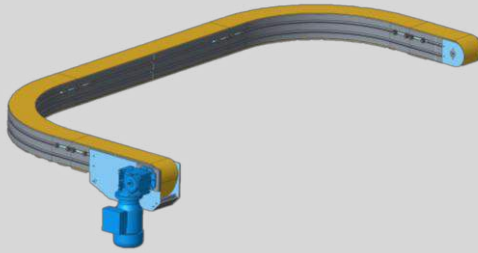

- Transportador de cadena articulada de ancho 114,3 o 190,5 mm con accionamiento por medio de motorreductor en posición central o extremo.
- Chasis en perfil de aluminio extrusionado.
- Guías de deslizamiento de la cadena sobre el chasis en acero sulfinado para altas temperaturas (-70°C a +430°C).
- Calidades de las cadenas articuladas:
  - Cadena de aleaciones de acero inoxidable ferrítico de alta calidad AISI 430 (-70°C a +430°C) magnético.
  - Cadena de aleaciones de acero inoxidable austenítico de alta calidad AISI 304 (-70°C a +430°C) no magnético.
  - Cadena de aleaciones de acero de alta calidad tratado y templado con carbono (-70°C a +430°C), magnético.
- Placas de amarre del motorreductor en duraluminio anodizado.
- Eje, piñón motriz y reenvío de acero pavonado.
- Tensor de cadena en el reenvío.
- Rodamientos a bolas autolineables con engrase de por vida.
- Curvas standard: 90° y 180° - Radio: 500 mm. Posibilidad de curvas con diferentes radios y grados.





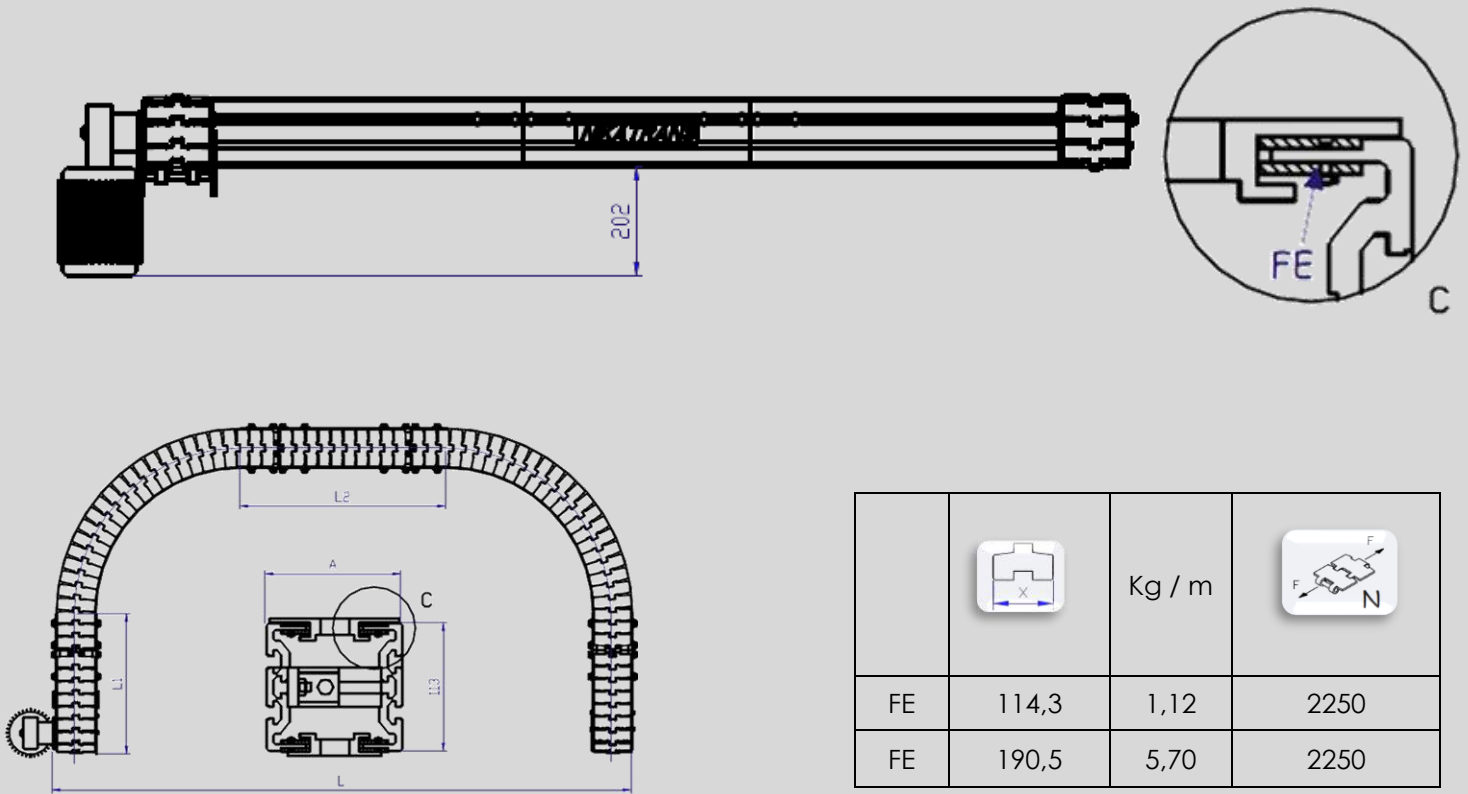

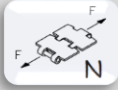

- Slat chain conveyor with width of 114,3 mm or 190,5 mm driven by gear motor located in center or at the end.
- Standard slide guide on top of frame for the chain in PET (-40°C to +80°C)
- Slide guide on top of frame in sulfined steel for high temperatures (-70°C to + 430°C)
- Qualities of the steel chains:
  - High quality ferritic stainless steel alloy chain AISI 430 (-70°C to +430°C) magnetic
  - High quality austenitic stainless steel alloy chain AISI 304 (-70°C to +430°C) non-magnetic
  - High quality treated and hardened carbon steel alloy chain (-70°C to +430°C) magnetic.
- Gear motor flanges of anodised duraluminium.
- Blue steel shaft, drive and return pinion.
- Chain tensor located at return end of conveyor.
- Auto-alignable bearings with greasing for life.
- Standard curves: 90° and 180° - Radius: 500 mm. Possibility curves with different radius and grades.



		Kg / m	
FE	114,3	1,12	2250
FE	190,5	5,70	2250

### Información técnica / Technical information

	mm	120 / 200					
	mm	500 / 750					
	V	3 x 380					
	m / min	3,7	5,2	7,2	10	13,5	19
	Kg	150	150	100	100	100	100
	Kw	0,12	0,12	0,18	0,25	0,25	0,37
	Nm	60	54	38	47	35	41
	°C	(-70) - (+430)					

## NT 730 40

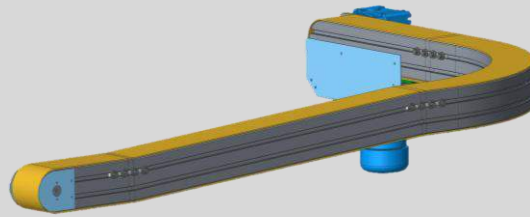

- Transportador de cadena articulada con inflexión de ancho 114,3 o 190,5 mm con accionamiento por medio de motorreductor en posición central o extremo.
- Chasis en perfil de aluminio extrusionado.
- Guía estándar de deslizamiento de la cadena:
  - PET (-40°C a +80°C)
  - Acero sulfinado para altas temperaturas (-70°C a +430°C).
- Calidades de las cadenas articuladas:
  - Cadena de aleaciones de acero inoxidable ferrítico de alta calidad AISI 430 (-70°C a +430°C) magnético.
  - Cadena de aleaciones de acero inoxidable austénico de alta calidad AISI 304 (-70°C a +430°C) no magnético.
  - Cadena de aleaciones de acero de alta calidad tratado y templado con carbono (-70°C a +430°C). magnético.
- Placas de amarre del motorreductor en duraluminio anodizado.
- Eje, piñón motriz y reenvío de acero pavonado.
- Tensor de cadena en el reenvío.
- Rodamientos a bolas autolineables con engrase de por vida.
- Curvas standard: 90° y 180° - Radio: 500 mm. Posibilidad de curvas con diferentes radios y grados.





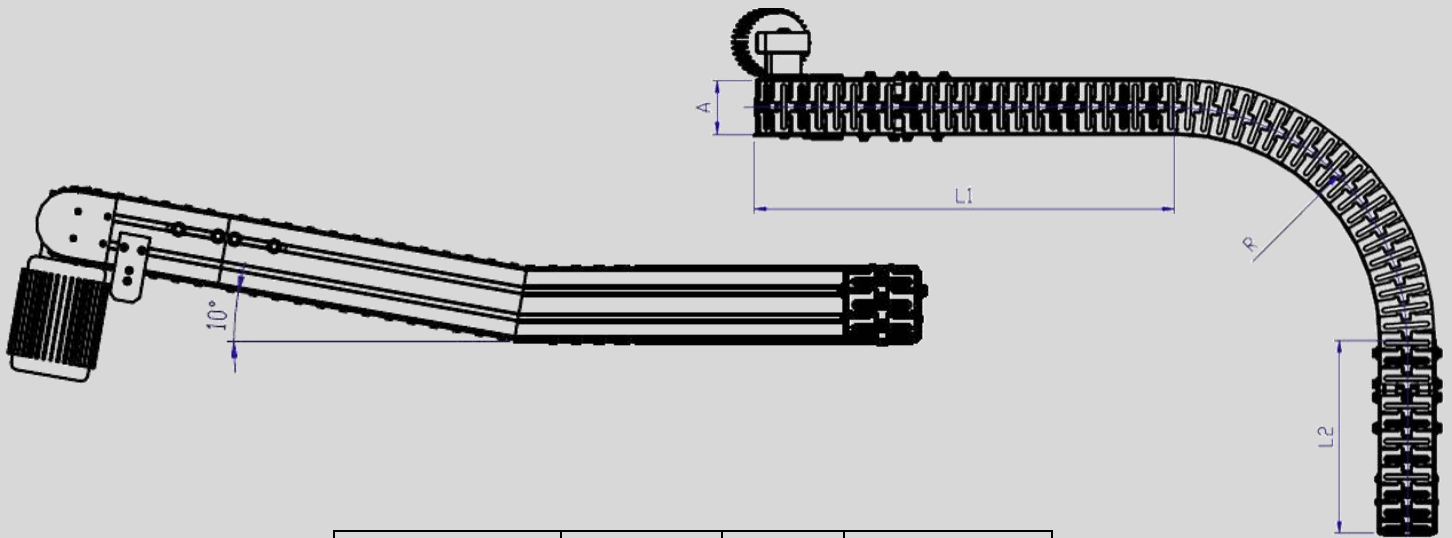

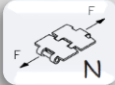
- Slat chain conveyor with width of 114,3 mm or 190,5 mm driven by gear motor located in center or at the end.
- Standard slide guide
  - PET (-40°C to +80°C)
  - Sulfined steel for high temperatures (-40°C to +430°C)
- Qualities of the steel chains:
  - High quality ferritic stainless steel alloy chain AISI 430 (-70°C to +430°C) magnetic
  - High quality austenitic stainless steel alloy chain AISI 304 (-70°C to +430°C) non-magnetic
  - High quality treated and hardened carbon steel alloy chain (-70°C to +430°C) magnetic.
- Gear motor flanges of anodised duraluminium.
- Blue steel shaft, drive and return pinion.
- Chain tensor located at return end of conveyor.
- Auto-alignable bearings with greasing for life.
- Standard curves: 90° and 180° - Radius: 500 mm. Possibility curves with different radius and grades.

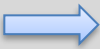

		Kg / m	
FE	114,3	1,12	2250
FE	190,5	5,70	2250

### Información técnica / Technical information

A	mm	120 / 200					
R	mm	500 / 700					
	V	3 x 380					
	m / min	3,7	5,2	7,2	10	13,5	19
	Kg	70	85	100	100	100	85
	Kw	0,09	0,09	0,18	0,18	0,18	0,18
	Nm	12	14	18	18	17	16
	°C	(-40) - (+90)					

## NT 730 50

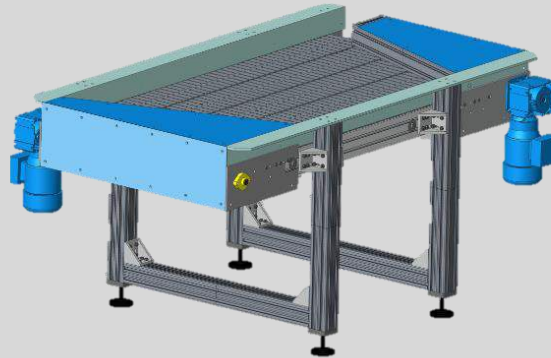

- Pulmón por medio de transportador de cadena articulada con de ancho 114,3 o 190,5 mm con doble accionamiento por medio de motorreductor en posición extremo.
- Chasis en perfil de aluminio extrusionado.
- Guía estándar de deslizamiento de la cadena:
  - PET (-40°C a + 80°C)
  - Acero sulfinado para altas temperaturas (-70°C a +430°C).
- Calidades de las cadenas articuladas:
  - Cadena de aleaciones de acero inoxidable ferrítico de alta calidad AISI 430 (-70°C a +430°C) magnético.
  - Cadena de aleaciones de acero inoxidable austénico de alta calidad AISI 304 (-70°C a +430°C) no magnético.
  - Cadena de aleaciones de acero de alta calidad tratado y templado con carbono (-70°C a +430°C). magnético.
- Placas de amarre del motorreductor en duraluminio anodizado.
- Eje, piñón motriz y reenvío de acero pavonado.
- Tensor de cadena en el reenvío.
- Rodamientos a bolas autolineables.



- Buffer and storage with slat chain conveyor with width of 114,3 mm or 190,5 mm driven by gear motor located at the end.
- Standard slide guide
  - PET (-40°C to +80°C)
  - Sulfined steel for high temperatures (-40°C to + 430°C)
- Qualities of the steel chains:
  - High quality ferritic stainless steel alloy chain AISI 430 (-70°C to +430°C) magnetic
  - High quality austenic stainless steel alloy chain AISI 304 (-70°C to +430°C) non-magnetic
  - High quality treated and hardened carbon steel alloy chain (-70°C to +430°C) magnetic.
- Gear motor flanges of anodised duraluminium.
- Blue steel shaft, drive and return pinion.
- Chain tensor located at return end of conveyor.
- Auto-alignable bearings with greasing for life.

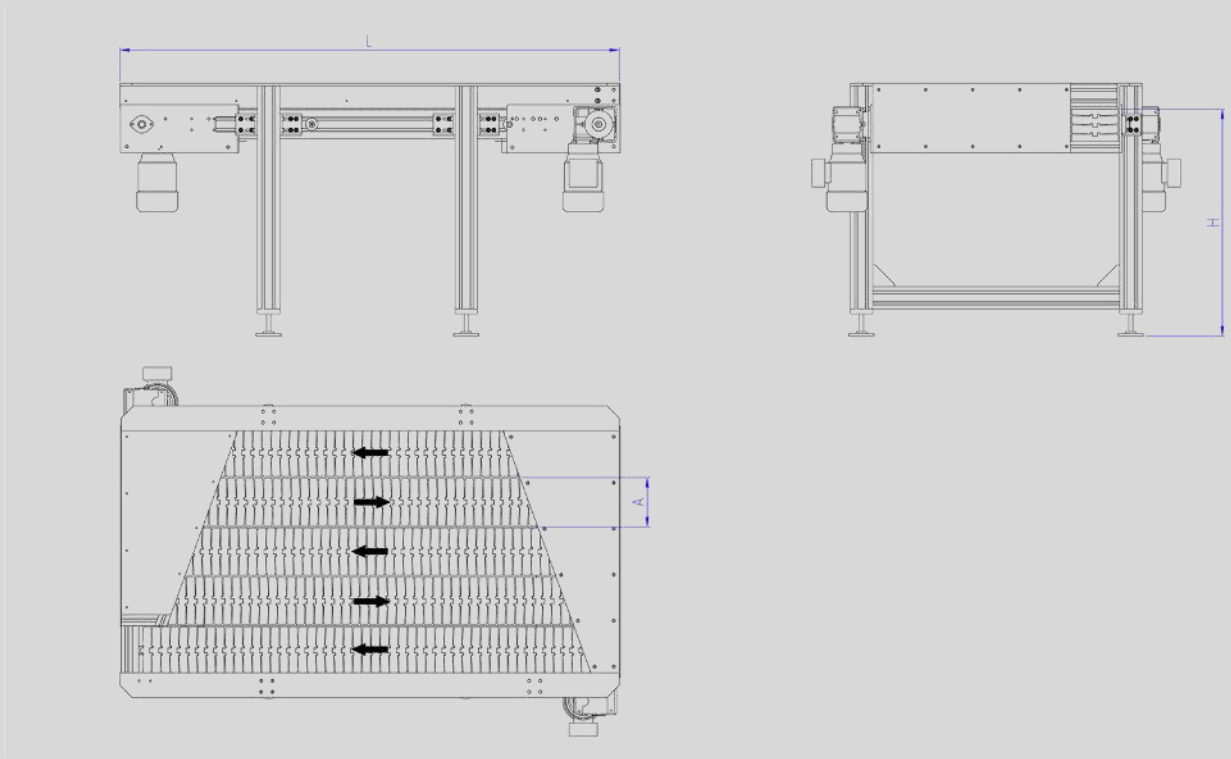

Información técnica / Technical information

A	mm	120 / 200					
	V	3 x 380					
	m / min	3,7	5,2	7,2	10	13,5	19
	Kg	300	300	200	200	200	200
	Kw	0,12	0,12	0,18	0,25	0,25	0,37
	Nm	60	54	38	47	35	41
	°C	(-40) - (+90) / (-70) - (+430)					

## NT 730 60

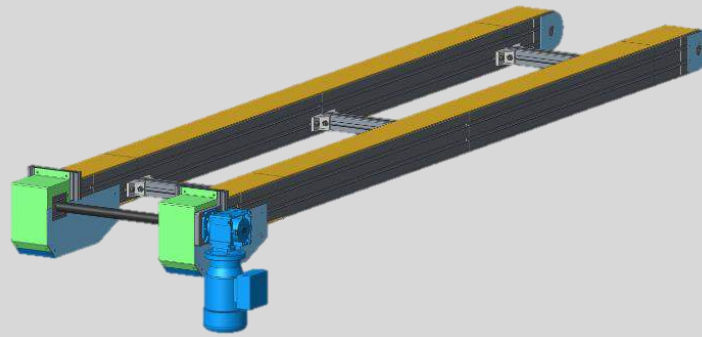

- Transportador de cadena articulada en tandem con de ancho 114,3 o 190,5 mm con accionamiento por medio de motorreductor en posición extremo.
- Chasis en perfil de aluminio extrusionado.
- Guía estándar de deslizamiento de la cadena:
  - PET (-40°C a +80°C)
  - Acero sulfinado para altas temperaturas (-70°C a +430°C).
- Calidades de las cadenas articuladas:
  - Cadena de aleaciones de acero inoxidable ferrítico de alta calidad AISI 430 (-70°C a +430°C) magnético.
  - Cadena de aleaciones de acero inoxidable austénico de alta calidad AISI 304 (-70°C a +430°C) no magnético.
  - Cadena de aleaciones de acero de alta calidad tratado y templado con carbono (-70°C a +430°C). magnético.
- Placas de amarre del motorreductor en duraluminio anodizado.
- Eje, piñón motriz y reenvío de acero pavonado.
- Tensor de cadena en el reenvío.
- Curvas standard: 90° y 180° - Radio: 500 mm. Posibilidad de curvas con diferentes radios y grados.



- Rodamientos a bolas autolineables con engrase de por vida.
- Slat chain conveyor in tandem with width of 114,3 mm or 190,5 mm driven by gear motor located at the end.
- Standard slide guide
  - PET (-40°C to +80°C)
  - Sulfurized steel for high temperatures (-40°C to +430°C)
- Qualities of the steel chains:
  - High quality ferritic stainless steel alloy chain AISI 430 (-70°C to +430°C) magnetic
  - High quality austenitic stainless steel alloy chain AISI 304 (-70°C to +430°C) non-magnetic
  - High quality treated and hardened carbon steel alloy chain (-70°C to +430°C) magnetic.
- Gear motor flanges of anodised duraluminium.
- Blue steel shaft, drive and return pinion.
- Chain tensor located at return end of conveyor.
- Auto-alignable bearings with greasing for life.
- Standard curves: 90° and 180° - Radius: 500 mm. Possibility curves with different radius and grades



# NT 700

Sistemas especiales  
Special systems

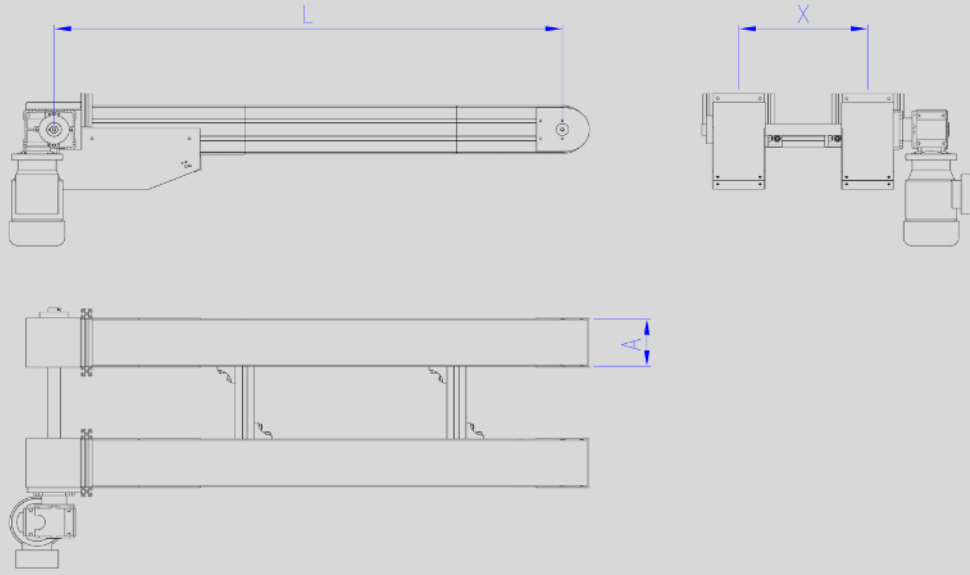

A	mm	80 / 120 / 200						
L	mm	3000						
	V	3 x 380						
	m / min	3,7	5,2	7,2	10	13,5	19	
	Kg	300	300	200	200	200	200	
	Kw	0,12	0,12	0,18	0,25	0,25		0,37
	°C	(-40) – (+90) / (-70) – (+430)						
	Nm	60	54	38	47	35		41

		Kg / m	
FE	114,3	3,90	2250
FE	190,5	5,70	2250
INOX	114,3	3,90	2250
INOX	190,5	5,70	2250
LF	114,3	1,12	2250
LF	190,5	2,34	2250

## NT 730 65

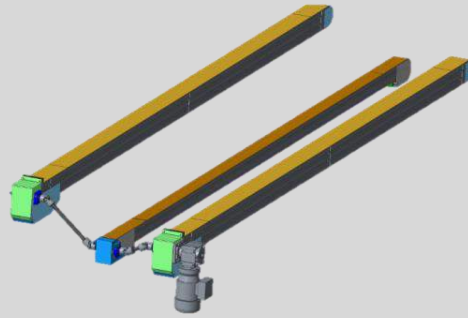

- Transportador de cadena articulada en tandem con de ancho 114,3 o 190,5 mm con accionamiento por medio de motorreductor en posición extremo.
  - Chasis en perfil de aluminio extrusionado.
  - Guía estándar de deslizamiento de la cadena:
    - PET (-40°C a + 80°C)
    - Acero sulfinado para altas temperaturas (-70°C a +430°C).
  - Calidades de las cadenas articuladas:
    - Cadena de aleaciones de acero inoxidable ferrítico de alta calidad AISI 430 (-70°C a +430°C) magnético.
    - Cadena de aleaciones de acero inoxidable austénico de alta calidad AISI 304 (-70°C a +430°C) no magnético.
    - Cadena de aleaciones de acero de alta calidad tratado y templado con carbono (-70°C a +430°C). magnético.
  - Placas de amarre del motorreductor en duraluminio anodizado.
  - Eje, piñón motriz y reenvío de acero pavonado.
  - Tensor de cadena en el reenvío.
  - Curvas standard: 90° y 180° - Radio: 500 mm. Posibilidad de curvas con diferentes radios y grados.
  - Rodamientos a bolas autolineables con engrase de por vida.
- Slat chain conveyor in tandem with width of 114,3 mm or 190,5 mm driven by gear motor located at the end.
  - Standard slide guide
    - PET (-40°C to +80°C)
    - Sulfined steel for high temperatures (-40°C to +430°C)
  - Qualities of the steel chains:
    - High quality ferritic stainless steel alloy chain AISI 430 (-70°C to +430°C) magnetic
    - High quality austenic stainless steel alloy chain AISI 304 (-70°C to +430°C) non-magnetic
    - High quiality treated and hardened carbon steel alloy chain (-70°C to +430°C) magnetic.
  - Gear motor flanges of anodised duraluminium.
  - Blue steel shaft, drive and return pinion.
  - Chain tensor located at return end of conveyor.
  - Auto-alignable bearings with greasing for life.
  - Standard curves: 90° and 180° - Radius: 500 mm. Possibility curves with diferent radius and grades

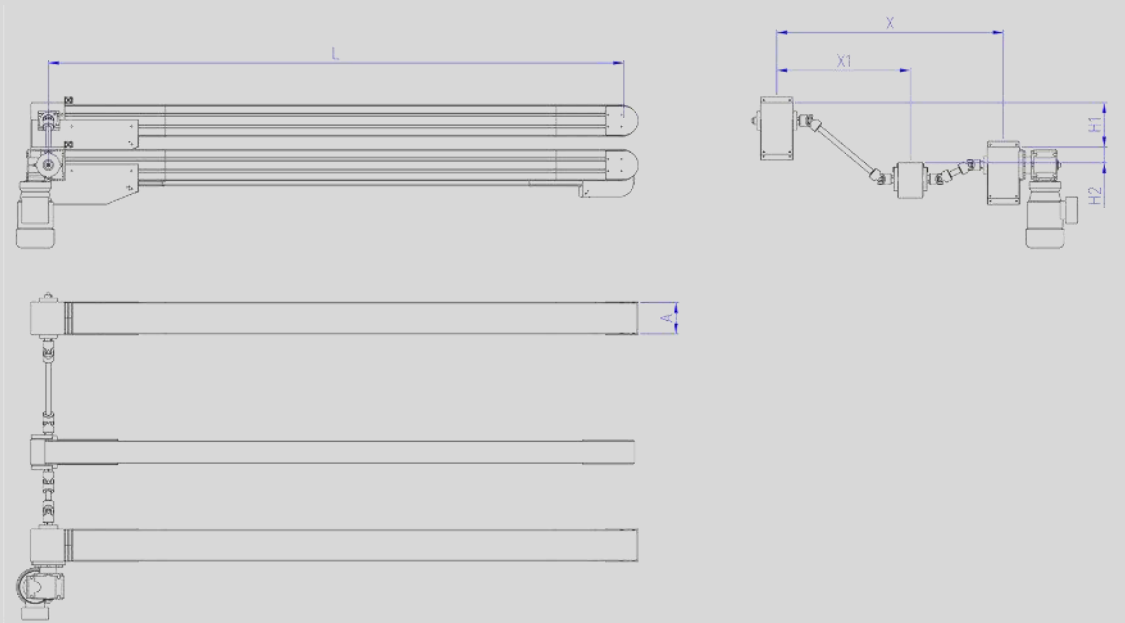

### Información técnica / Technical information

A	mm	80 / 120 / 200					
L	mm	3000					
	V	3 x 380					
	m / min	3,7	5,2	7,2	10	13,5	19
	Kg	300	300	200	200	200	200
	Kw	0,12	0,12	0,18	0,25	0,25	0,37
	°C	(-40) – (+90) / (-70) – (+430)					
	Nm	60	54	38	47	35	41

		Kg / m	
FE	114,3	3,90	2250
FE	190,5	5,70	2250
INOX	114,3	3,90	2250
INOX	190,5	5,70	2250
LF	114,3	1,12	2250
LF	190,5	2,34	2250

## NT 740 10

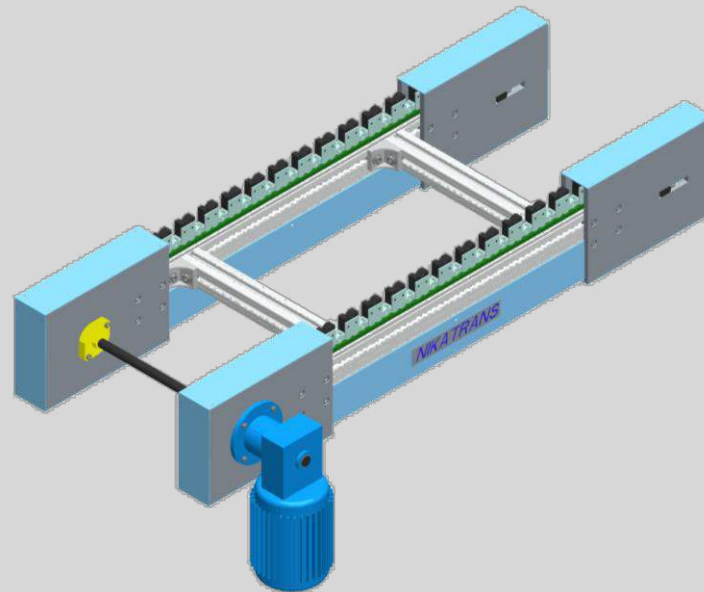

- Transportador de cadena de  $\frac{3}{4}$ " con utillajes de apoyo de doble vía con accionamiento por medio de motorreductor en posición extremo.
- Utillaje fabricados en plástico o acero según necesidad.
- Chasis construido con perfil de aluminio extrusionado.
- Placas de amarre de los piñones motrices y reenvíos de duraluminio anodizado.
- Rodamientos a bolas autolineables con engrase de por vida.
- Lecho de apoyo de la cadena en PET o acero tratado.
- Posibilidad de montar motorreductor con freno.



- $\frac{3}{4}$ " chain conveyor with double supports with tooling, drive by gear motor located at the end.
- Tooling can be either steel or plastic according to need.
- Extruded aluminium profile frame.
- Anodised duraluminium drive and return pinion flanges.
- Ball bearings with greasing for life.
- Treated sheet steel bed support for chain.



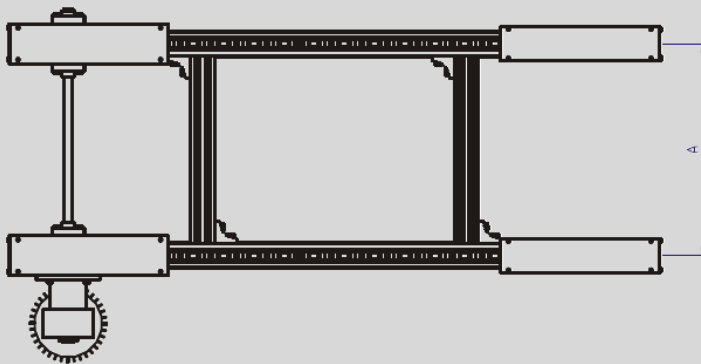
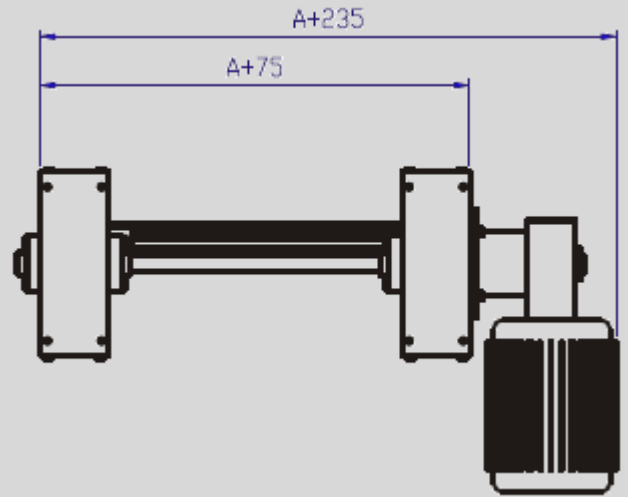
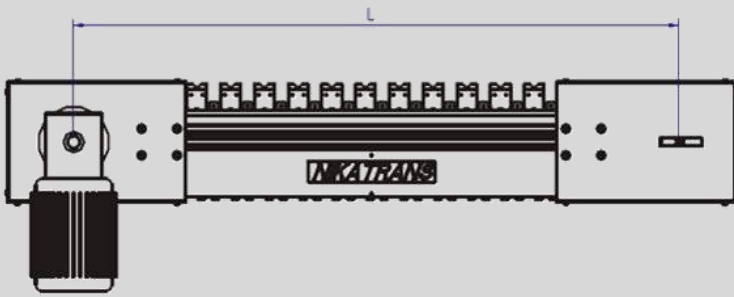

# NT 700

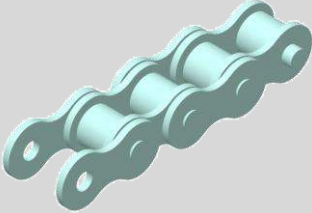
Sistemas especiales  
Special systems



Kg / m <sup>2</sup>	P	 N
1,5	3/4"	29000
		

## Información técnica / Technical information

A	mm	90 / 1000				
L	mm	3000				
	V	3 x 380				
	m / min	5	8	11	15	20
	Kg	90	50	50	80	50
	Kw	0,12	0,12	0,18	0,25	0,25
	Nm	54	25	31	35	27

## NT 750 10

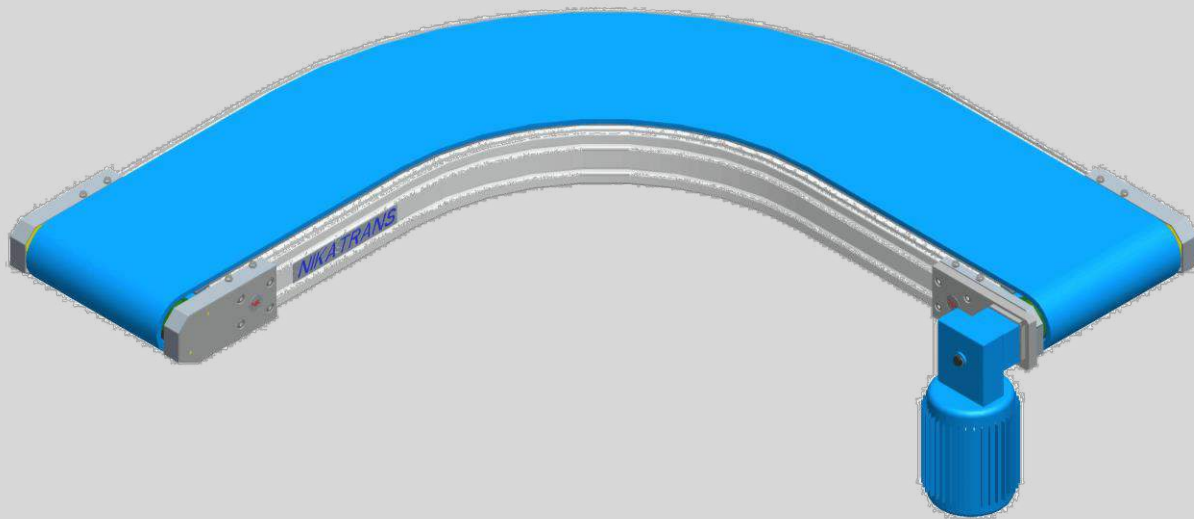

- Transportador de banda articulada en curva de 90° con accionamiento por motorreductor en posición extremo.
- Chasis construido en perfil de aluminio extrusionado.
- Rodillos de apoyo de banda articulada en ramal de retorno en tubo de aluminio de Ø50mm anodizado.
- Placas de amarre de los tambores en duraluminio anodizado.
- Tambores motriz y reenvío de eje cuadrado 40 mm en acero zincado.
- Piñones de arrastre de banda articulada de poliamida.
- Diámetro exterior de la banda engranada en los tambores 100 mm.
- Rodamiento a bolas con engrase de por vida.
- Lecho de apoyo de tela en chapa de acero galvanizada o de acero inoxidable.



- 90° modular plastic belt conveyor drive by gear motor located at end.
- Extruded aluminium profile frame.
- Ø50mm unpainted anodised duraluminium drum flanges.
- Unpainted anodised duraluminium drum flanges.
- Drive and return drums with Ø40mm zinc plated steel square shaft.
- Polyamide slat chain pinions.
- Outside diameter of 100 where the drums turn the belt.
- Ball bearings greasing for life.
- Galvanized or stainless sheet steel bed support for belt.

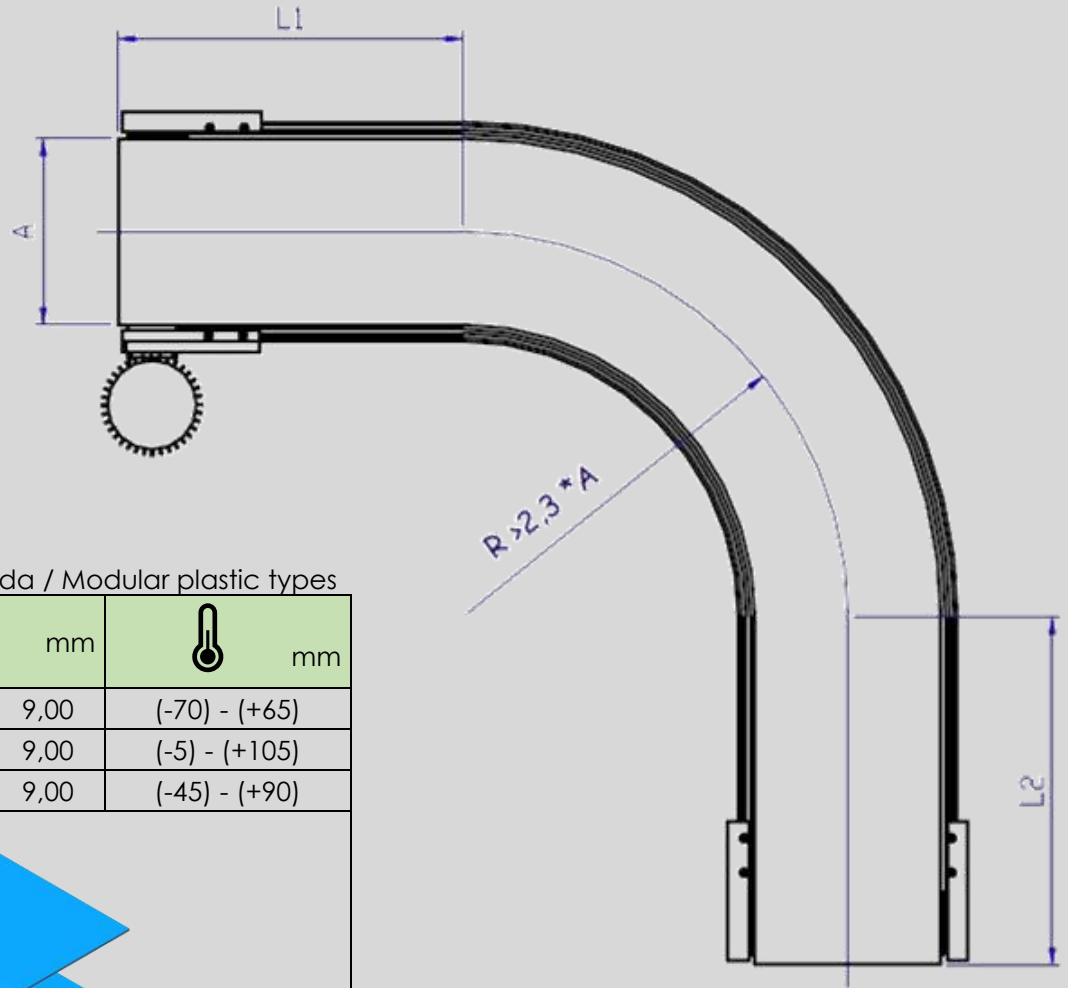

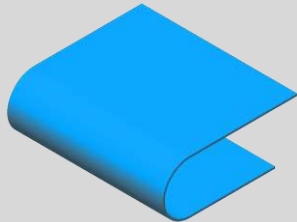

Tipo de banda articulada / Modular plastic types

	Kg / m <sup>2</sup>	mm	 mm
<b>PE</b>	3,40	9,00	(-70) - (+65)
<b>PP</b>	3,30	9,00	(-5) - (+105)
<b>LF</b>	4,80	9,00	(-45) - (+90)

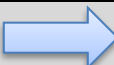

Información técnica / Technical information

P	mm	1" (25,4 mm)				
L	mm	Max. 5000				
	V	3 x 380				
	m / min	7,5	10	13,5	20	30
	Kg	80	60	50	60	60
	Kw	0,12	0,12	0,12	0,18	0,25
	Nm	18	15	12	16	16

## NT 760 10

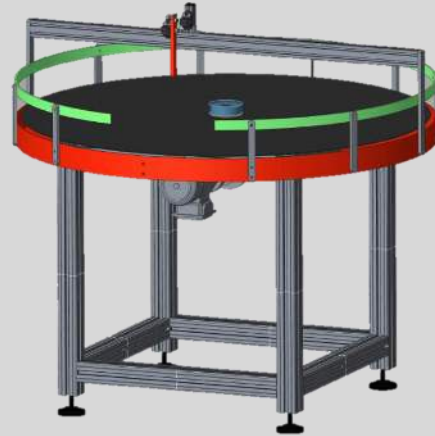
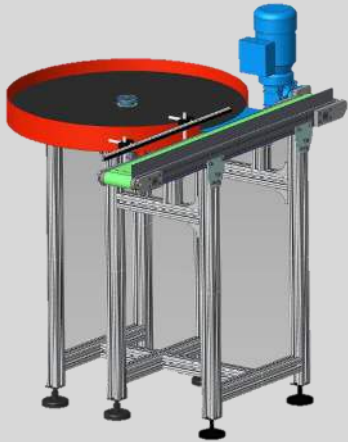

- Pulmón dosificador con disco de giro dotado de transportador para evacuar o insertar piezas. Tipos de transportadores adjuntos:
  - NT 100 Transportador de banda
  - NT 300 Transportador de cadena articulada.
  - NT 500 Transportador de banda modular.
- Disco de giro de con accionamiento por medio motorreductor en posición inferior.
- Chasis construido en perfil de aluminio.
- Embrague mecánico para evitar atrapamientos.



- Chassis built in aluminum profile.
- Mechanical clutch to avoid entrapments.
- Accumulation buffer with rotating disc equipped with a conveyor to evacuate or insert parts. Types of attached conveyors:
  - NT 100 Band conveyor
  - NT 300 articulated chain conveyor.
  - NT 500 Modular belt conveyor.
- Rotating disc with drive by means of gearmotor in lower position.



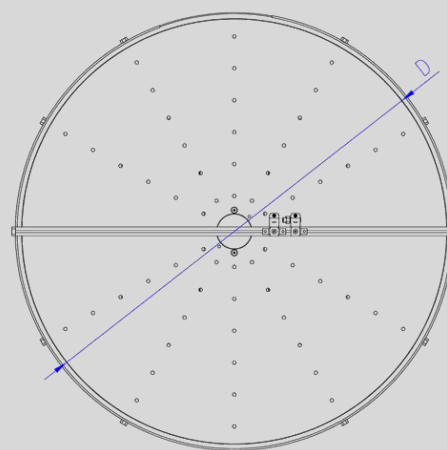
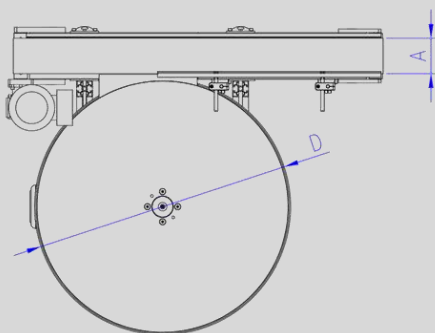
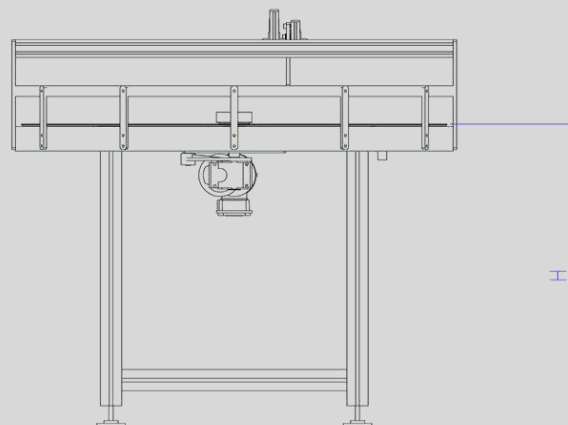
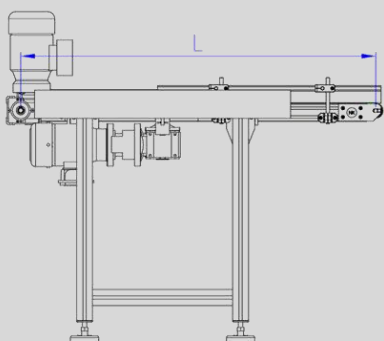

## Tipos de guía / Type of guides

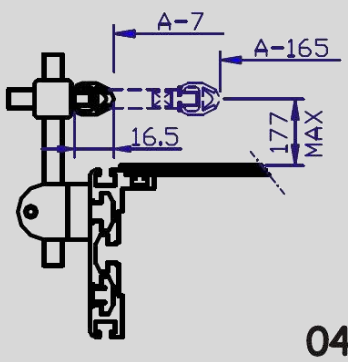

04

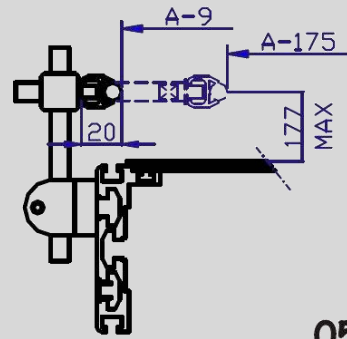

05

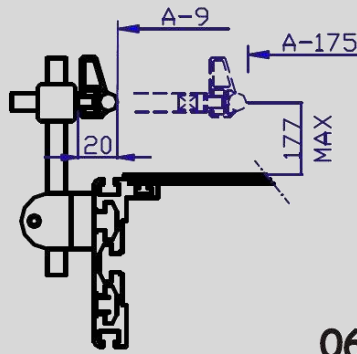

06